

Simplifying Electricity

Intermediate electrical and electronic principles

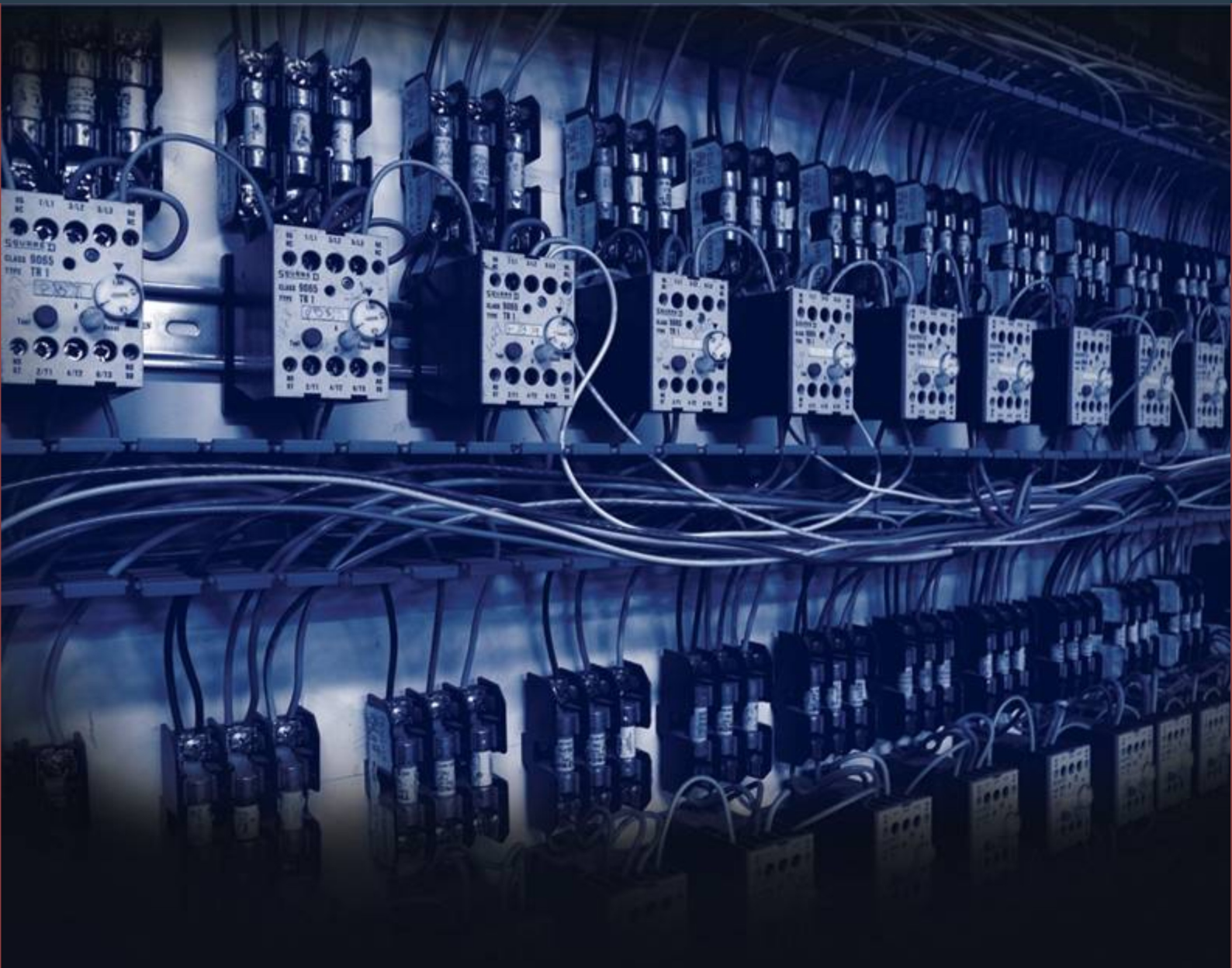

LK4583

MATRIX
www.matrixmultimedia.com

Copyright © 2009 Matrix Multimedia Limited

Contents

Intermediate electrical and electronic principles

Worksheet 1 - Cells and batteries	3
Worksheet 2 - Current measurement	5
Worksheet 3 - Voltage measurement	7
Worksheet 4 - Ohms Law	9
Worksheet 5 - Series and parallel circuits	11
Worksheet 6 - Voltage dividers	13
Worksheet 7 - Current dividers	15
Worksheet 8 - Using Kirchhoff's Laws	17
Worksheet 9 - Power in DC circuits	19
Worksheet 10 - Electrostatics and capacitors	21
Worksheet 11 - Capacitor charge and discharge	23
Worksheet 12 - Electromagnetism	25
Worksheet 13 - Inductors and inductance	27
Worksheet 14 - AC measurements	29
Worksheet 15 - AC and inductors	31
Worksheet 16 - AC and capacitors	33
Worksheet 17 - L-R series circuit	35
Worksheet 18 - C-R series circuit	37
Worksheet 19 - L-C-R series circuit	39
Worksheet 20 - Transformers	41
Worksheet 21 - Practical transformers	43
Worksheet 22 - Diode characteristics	45
Worksheet 23 - Half-wave rectifier	47
Worksheet 24 - Full-wave bridge rectifier	49
Revision questions	51
Answers to revision questions	54
Tutor's notes	55
Answers to worksheet questions	70

About this document:

Code: LK4583

Developed for product code LK9862 - Further electronic engineering

Date	Release notes	Release version
18 04 2012	First version released	LK4583-I Version I
19 08 15	Renamed—was 'Advanced'.	LK4583-3

Worksheet 1

Cells and batteries

Intermediate electrical and electronic principles

Many different types of battery are used to provide the power supplies in electrical and electronic equipment.

They can be categorized by materials used in them.

Types include **lead-acid**, **nickel-cadmium** (NiCad) and **nickel metal hydride** (NiMH).

Here are the e.m.f.'s of some single-cell batteries:

Alkaline (primary dry cell)	1.5
V	
Lead-acid (secondary cell)	2 V
Nickel-cadmium (secondary cell)	1.2 V
Nickel-metal hydride (secondary cell)	1.2 V
Zinc-carbon (primary dry cell)	1.5 V



The cells within them can be either **primary** (non-rechargeable) or **secondary** (rechargeable). In primary cells, the active constituents are used up at the end of the cell's life, whereas for secondary cells, the chemical reaction is reversible and the cell can be re-charged many times.

Batteries consist of a number of individual cells connected in series or in parallel. For example, a 24 V lead-acid battery will usually have 12 cells (each with an e.m.f. of 2 V) connected in series.

This first worksheet examines batteries and the cells within them.

Over to you:

- Set up each of the **series-connected battery** arrangements shown opposite. The diagram below shows one way of arranging the cells on the baseboard.
- For each, use a multimeter (set to the 20 V DC range) to measure the output voltage.
- For the single-cell battery (a), measure the voltage, **E1**.
- For the two-cell battery (b), check that the voltage, $V = E1 + E2$
- For the three-cell battery (c), check that $V = E1 + E2 + E3$

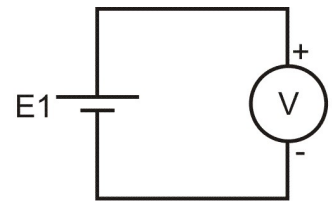

(a)

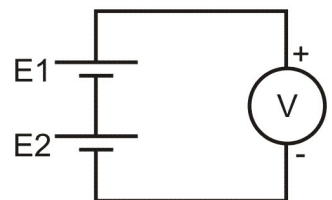

(b)

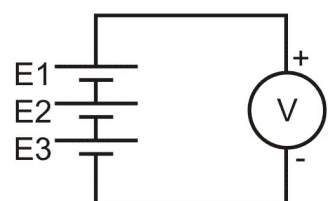

(c)

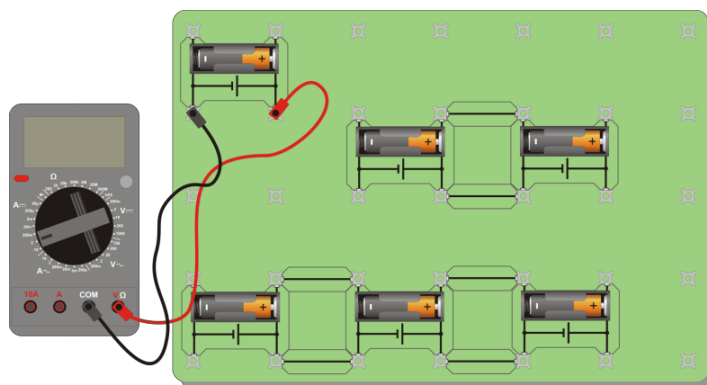

Worksheet 1

Cells and batteries

Intermediate electrical and electronic principles

Over to you:

- Set up each of the **parallel-connected battery** arrangements shown opposite.
- For each use measure the output voltage.
- For the single-cell battery (a), measure voltage **E1**.
- For the two-cell battery (b), check that the voltage, $V = E1 = E2$.
- For (c), check that $V = E1 = E2 = E3$.

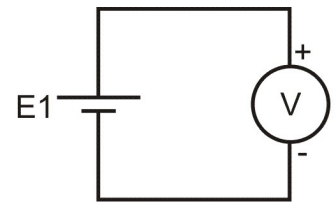

(a)

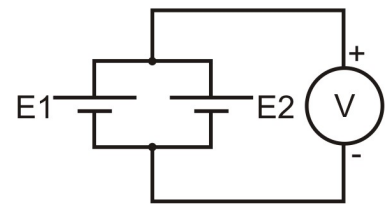

(b)

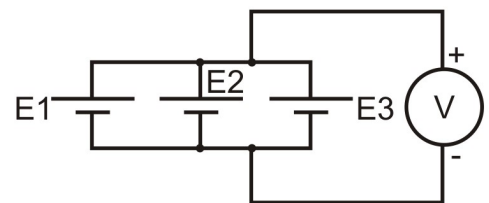

(c)

For your records:

- Summarise your findings for voltages in series-connected cells.
- Summarise your findings for voltages in parallel-connected cells.
- With a series-connected battery the *same* load current flows through each of the cells.
- With a parallel-connected battery the load current is *shared* between the cells.

Questions

1. How many nickel-cadmium cells are required in a series-connected 24V battery?
2. Two batteries are connected in parallel to supply 180A for an engine starter motor. How much current is supplied by each battery?
3. An emergency lamp uses eight 1.5V dry-cells connected in series. What voltage is applied to the lamp?
4. A 24V battery supplies 18 parallel-connected emergency lights. Each light requires 1.5A. What current is supplied by the battery?
5. Why should parallel connection of dissimilar types of batteries be avoided?

Answers are provided on page 70.

Worksheet 2

Current measurement

Intermediate electrical and electronic principles



The symbols for three electrical meters are shown on the right. Ammeters measure current, voltmeters measure voltage (*potential difference*) and ohmmeters measure resistance.

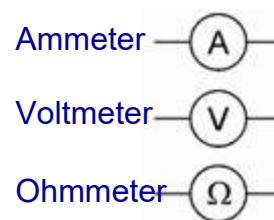

They are often combined as a multimeter, which offers a convenient and cheap way to measure a range of electrical quantities. The photograph shows a typical multimeter. It can measure both AC and DC quantities, and the symbols shown opposite distinguish between the two:



This worksheet shows you how to use a multimeter to measure the current flowing in a circuit.

Over to you:

A. Series circuit:

- Set up the arrangement shown, using 12V 0.1A bulbs.
- Make sure that the power supply is set to 12V.
- This is a **series** circuit - There is only one route for the electric current to flow around the circuit.
- Measure the current flowing at point **P**.
To do this, plug the wires from the ammeter into the posts at the ends of the link at point **P**, and remove the link. This is shown in the picture.
- Record the result in the table.
- Now replace the link at **P**.
- Measure and record the current at point **Q** in the same way.
- Next, measure and record the current at points **R** and **S**.

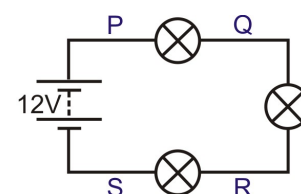

Position	P	Q	R	S
Current				

B. Parallel circuit:

- Set up the second circuit, again using 12V 0.1A bulbs.
- The power supply is still set to 12V.
- This is a **parallel** circuit - there are 'branches' in the circuit, and a number of ways for current to flow around it.
- Measure the current at the points shown in the circuit diagram and record them in the table given opposite:

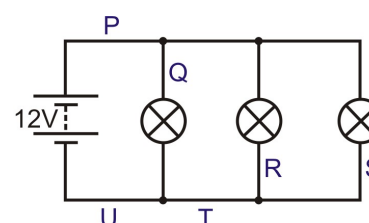

Position	P	Q	R	S	T	U
Current						

Worksheet 2

Current measurement

Intermediate electrical and electronic principles

So what?

Using a multimeter to measure current:

- Plug one wire into the black COM socket.
- Plug another into the red mA socket.
- Select the 200mA DC range by turning the dial to the '200m' mark next to the 'A 
- Break the circuit where you want to measure the current, by removing a link, and then plug the two wires in its place.
- Press the red ON/OFF switch when you are ready to take a reading.
- Change to a lower range if the reading allows it. (A '1' on the display means that the reading is too big for the chosen range.)

A possible problem!

The ammeter range is protected by a fuse located inside the body of the multimeter. This fuse may have 'blown', in which case the ammeter range will not work. Report any problems to your tutor so that the fuse can be checked.

A challenge:

The first circuit you built was a series circuit. The second was not. See if you can spot a pattern for the behaviour of currents in each of the circuits!

For your records:

Use your findings to complete the following statements:

- In a series circuit, the current flows in all parts.
- In a parallel circuit, the currents in all the parallel branches add up to the current leaving the

Copy the circuit diagrams given below, and calculate the readings on ammeters A to H.

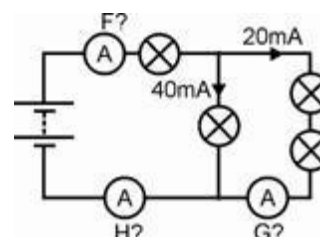
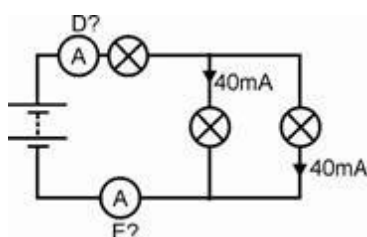
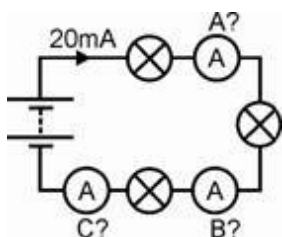

Worksheet 3

Voltage measurement

Intermediate electrical and electronic principles

We can visualise electric current easily - it's the flow of tiny electrons . More precisely, electric current measures the number of electrons per second passing a particular point in the circuit.

It's more difficult to picture voltage, but you can think of it as the pressure that causes the current to flow.

Fortunately, it's easier to measure voltage than current. There's no need to break the circuit - just add the voltmeter in parallel with the component you are interested in!

*Ammeters are connected **in series** but voltmeters are connected **in parallel!***

This worksheet shows you how to use a multimeter as a voltmeter.



Over to you:

A. Series circuit:

- Set up the arrangement shown, using 12V 0.1A bulbs, *but without the voltmeters.*
- Make sure that the power supply is set to 12V.
- This is a **series** circuit with only one route around it.
- Measure the voltage across the first bulb, shown as **P**.
To do this, plug the wires from the voltmeter into the posts at either end of the bulb. Don't remove any connecting links!
- Record the result in the table.
- Next, measure and record the voltage across the second bulb, **Q**, in the same way.
- Then measure and record the voltage across the bulb, **R**.

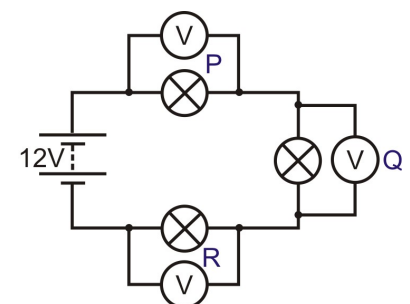

Position	P	Q	R
Voltage			

B. Parallel circuit:

- Set up the second circuit, again using 12V 0.1A bulbs.
- The power supply is still set to 12V.
- This is a **parallel** circuit - notice the 'branches' in the circuit.
- Measure the voltage at the points **P**, **Q** and **R** and record them in the table given opposite:

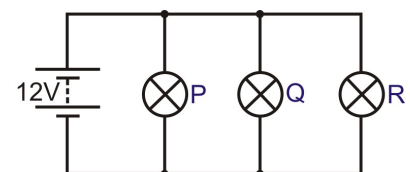

Position	P	Q	R
Voltage			

Worksheet 3

Voltage measurement

Intermediate electrical and electronic principles

So what?

Using a multimeter to measure voltage:

A multimeter can measure both AC and DC quantities. The symbols were given on the last worksheet.

- Plug one wire into the black COM socket.
- Plug another into the red V socket.
- Select the 20V DC range by turning the dial to the '20' mark next to the 'V  ' symbol. (It is good practice to set the meter on a range that is much higher than the reading you are expecting. Then you can refine the measurement by choosing a lower range that suits the voltage you find.)
- Plug the two wires into the sockets at the ends of the component under investigation.
- Press the red ON/OFF switch when you are ready to take a reading.
- If you see a '-' sign in front of the reading, it means that the voltmeter leads are connected the wrong way round. Swap them over to correct this!

Two challenges:

- Looking at the results for the first circuit, add together the readings of the voltmeters at points P, Q and R. What do you notice about this total?
- Find a pattern in the results for the behaviour of the second and third circuits.

For your records:

- In a series circuit, the voltages across the components add up to the voltage across the
- In a parallel circuit, the components all have the voltage across them.
- Copy the following circuit diagrams, and calculate the voltages across bulbs A to E.

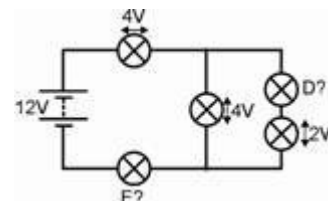
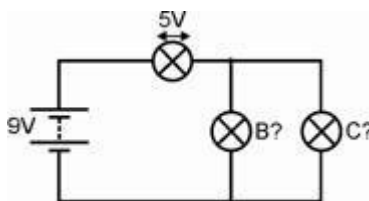
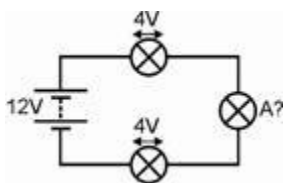

Worksheet 4

Ohm's Law

Intermediate electrical and electronic principles

Current I - how many electrons pass per second.

Voltage V - a measure of how much energy the electrons gain or lose as they flow around a circuit.

Resistance R - how difficult it is for the electrons to pass through a material. In squeezing through, the electrons lose energy to the resistor, which warms up as a result.

The photograph shows Georg Simon Ohm - a significant figure in the study of electrical and electronic principles!

Ohm's law leads to a very important relationship in electricity: $V = I$



Over to you:

- Build the circuit shown in the diagram.
- The picture shows one way to set this up.
- **Make sure that the power supply is set to 3V!**
- The variable resistor allows us to change the voltage across the 100Ω resistor.
- **Before you switch on**, select the **20mA DC** range on the ammeter, and the **20V DC** range on the voltmeter.
- Notice the positions of the red and black connecting wires. This ensures that the meters are connected the right way round to avoid '-' signs on the readings.
- Turn the knob on the variable resistor fully anticlockwise, to set the voltage supplied to a minimum.
- Turn the knob slowly clockwise until the voltage across the resistor reaches 0.1V. Then read the current flowing through the resistor.
- Turn the voltage up to 0.2V, and take the current reading again.
- Keep doing this until the voltage reaches 1.0V. (**Don't go past this or the resistor may overheat.**)
- Write your results in a table like the one opposite.

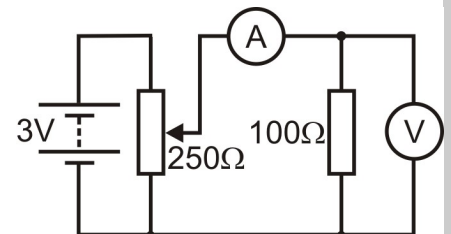

to ammeter

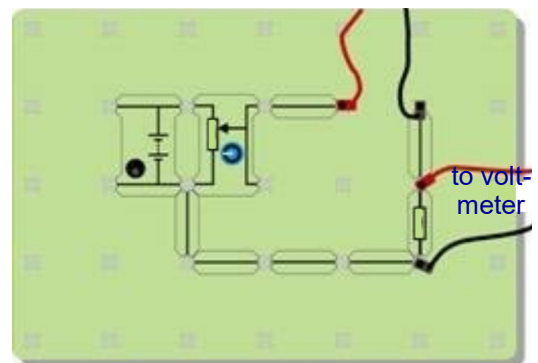

to voltmeter

Resistor voltage	Resistor current
0.1V	
0.2V	
⋮	⋮
1.0V	

Worksheet 4

Ohm's Law

Intermediate electrical and electronic principles

So what?

Using a multimeter to measure resistance:

You cannot measure resistance while the component is in the circuit. It must be removed first.

- Plug one wire into the black COM socket, and the other into the V Ω socket.
- Select the 200kΩ range, (or a range much higher than the reading you are expecting.)
- Plug wires into the two sockets at the ends of the component under investigation.
- Press the red ON/OFF switch when you are ready.
- Turn the dial to a lower range, until you find the reading.

A challenge:

- Plot a graph to show your results.
- Ohm's law predicts a straight line, so draw the best straight line through your points.
- If you know how, calculate the gradient of your graph. Ohm's law calls this quantity the **resistance** of the resistor.

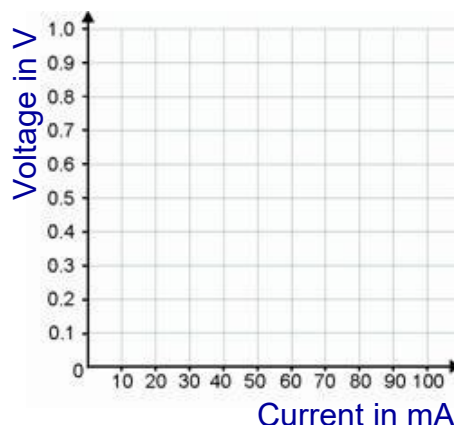

For your records:

- Ohm's law gives us the equations: $V = I \times R$ $R = V / I$ $I = V / R$
 where **R** = resistance in ohms, **I** = current in amps and **V** = voltage.
 (This also works with **R** in kilohms and **I** in milliamps, because the kilo and milli cancel out.)
- Copy the following diagrams, and calculate the missing quantities:

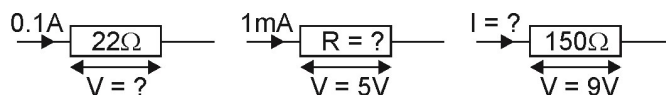

Resistor Colour Code:

Resistors come ringed with coloured bands to show the resistance value. Each colour represents a number, given in the table below.

Black	Brown	Red	Orange	Yellow	Green	Blue	Purple	Grey	White
0	1	2	3	4	5	6	7	8	9



read the colour code:

- start from the opposite end to the gold or silver band;
- write down the number shown by the first colour band;
- do the same for the second colour band;
- add the number of 0's shown in the next band (e.g. for red, add two 0's.)
- the final band gives the tolerance - how accurately it is made, (gold = 5%, silver = 10%.)

For the resistors in the photograph:

Resistance = 7 (purple) 5 (green) 000 (orange) = 75000Ω with a tolerance of 5%

Worksheet 5

Series and parallel circuits

Intermediate electrical and electronic principles

In nearly all electrical circuits, some components are connected in series, while others are in parallel.

To apply the rules that you learned earlier, you have to recognise which parts of a circuit are in series and which are in parallel.

In a complex circuit, components in parallel have the *same voltage* across them, but may carry *different currents*, while components in series have the *same current* flowing through them, but

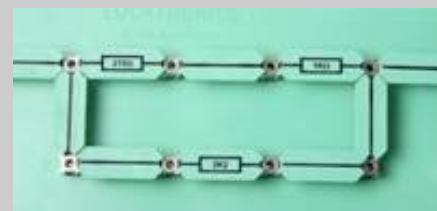

Over to you:

- Connect a 270Ω resistor, a 1kΩ resistor and a 2.2kΩ resistor, as shown in the diagram. The 270Ω and 1kΩ resistor are in series, while the 2.2kΩ resistor is in parallel with the combination.
- Use extra connecting links so that the current can be measured at points **A**, **B**, **C** and **D**. The photograph shows one way to do this.
- Set the power supply to give a 4.5V output.
- Remove the connecting link at **A**, and connect a multimeter to read the current. Record it in the table.
- Remove the multimeter and replace link **A**.
- Remove the connecting link at **B**, and use a multimeter to measure the current here. Record it in the table.
- In the same way, measure and record the current at points **C**, and **D**.
- Connect the multimeter to read the voltage across resistor **R₁**. Record it in the table.
- Then connect the multimeter up to read the voltage across **R₂** and **R₃**, in turn, and record them in the table.

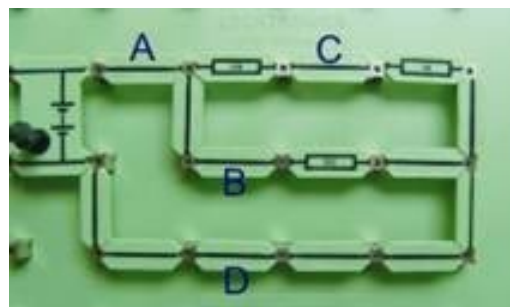
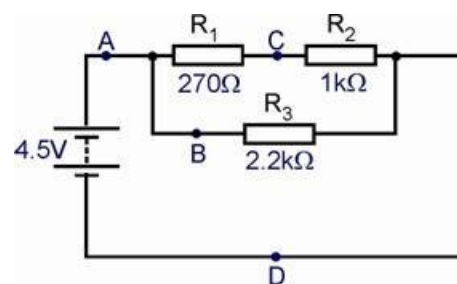

Power supply voltage	4.5V
Current at point A in mA	
Current at point B in mA	
Current at point C in mA	
Current at point D in mA	
Voltage across R₁ (270Ω resistor)	
Voltage across R₂ (1kΩ resistor)	
Voltage across R₃ (2.2kΩ resistor)	

Worksheet 5

Series and parallel circuits

Intermediate electrical and electronic principles

So what?

- The same current flows through R_1 and R_2 , as they are in series. This is the current you measured at point **C**.
- The current readings at **A** and **D** should be the same, as these measure the total current leaving and returning to the power supply.
- The current from the power supply splits, with part going through R_1 (and then R_2), while the rest flows through R_3 . In other words, adding together the readings at **B** and **C** should give a total equal to the reading at **A** (and **D**).
- The full power supply voltage appears across R_3 , but is split between R_1 and R_2 .
- Complete rows 1, 2 and 3 of the following table.

Power supply voltage	4.5V
Average of currents at A and D in mA (= I)	
Sum of currents at B and C in mA	
Sum of voltages across R_1 and R_2 (= V_S)	
Total resistance $R_T = V_S / I$	
Combined resistance of R_1 and R_2 (in series) (= R_C)	
Total resistance of all three resistors $R_T = R_C \times R_3 / R_C + R_3$	

- Complete the table by calculating the total resistance R_T of the three resistors by:
 - using I and V_S in the formula $R = V/I$;
 - adding together the resistance of R_1 and R_2 , as these are in series, to give R_C , their combined resistance, and then using $R_T = R_C \times R_3 / R_C + R_3$.
- Think of reasons why these two approaches might give different values for R_T . Which, do you think, gives the more reliable result?

Questions

For the circuit shown opposite, calculate:

1. The total resistance;
2. The current at **P**;
3. The voltage across R_3 , the $6k\Omega$ resistor;
4. The current at **R**;
5. The current at **Q**;
6. The voltage across R_1 , the $8k\Omega$ resistor.

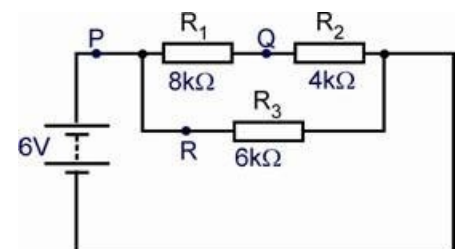

Answers are given on page 70.

Worksheet 6

Voltage dividers

Intermediate electrical and electronic principles

Resistors are used to protect other components from excessive current.

They can also be used in voltage dividers to split the voltage from a power supply into smaller predictable portions. This is particularly useful when one of the resistors is a sensing component, such as a LDR (light-dependent resistor,) or a thermistor, (temperature-dependent resistor.)

Voltage dividers form the basis of many sensors. The output voltage can represent temperature, light-level, pressure, humidity, strain or other physical quantities.



Over to you:

- Connect two 10kΩ resistors in series, as shown in the circuit diagram.
- Set the power supply to give a 6V output.
- Remove the connecting link at **A**, and connect a multimeter, set on the 2mA DC range, to measure the current. Record the value in the table.
- Remove the multimeter and replace link **A**.
- Set up the multimeter to read DC voltages of about 5V, and connect it to read the voltage across resistor **R**₁, and then across **R**₂. Record these in the second column of the table.
- Next, set the power supply to 9V, and repeat the measurements. Record them in the third column of the table.

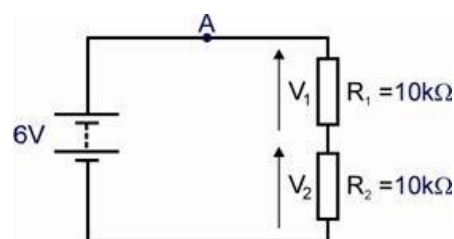

R₁ = 10kΩ, R₂ = 10kΩ		
Power supply voltage	6V	9V
Current at point A in mA		
Voltage V ₁ across R ₁		
Voltage V ₂ across R ₂		

- Now, swap resistor **R**₁ for a 1kΩ resistor. Repeat the process and record the results in the second table.
- Finally, replace both resistors, with a 2.2kΩ resistor for **R**₁, and a 22kΩ resistor for **R**₂. Repeat the measurements and record them in the third table.

R₁ = 1kΩ, R₂ = 10kΩ	
Power supply voltage	9V
Current at point A in mA	
Voltage V ₁ across R ₁	
Voltage V ₂ across R ₂	

R₁ = 2.2kΩ, R₂ = 22kΩ	
Power supply voltage	9V
Current at point A in mA	
Voltage V ₁ across R ₁	
Voltage V ₂ across R ₂	

Worksheet 6

Voltage dividers

Intermediate electrical and electronic principles

So what?

First of all, look at the theoretical behaviour of this circuit -

- Resistors R_1 and R_2 are connected in series. Their total resistance, is given by:

$$R_T = (R_1 + R_2).$$

- The full power supply voltage, V_S , appears across this total resistance, R_T , and so the current I , flowing through the two resistors is given by:

$$I = V_S / R_T$$

- The voltage across resistor R_1 is given by:

$$V_1 = I \times R_1$$

- The voltage across resistor R_2 is given by:

$$V_2 = I \times R_2$$

- Calculate R_T , I , R_1 and R_2 for each of the circuits looked at, and complete the next table with your results:

Circuit	R_T	I	V_1	V_2
$R_1 = 10k\Omega$, $R_2 = 10k\Omega$, $V_S = 6V$				
$R_1 = 10k\Omega$, $R_2 = 10k\Omega$, $V_S = 9V$				
$R_1 = 1k\Omega$, $R_2 = 10k\Omega$, $V_S = 9V$				
$R_1 = 2.2k\Omega$, $R_2 = 22k\Omega$, $V_S = 9V$				

- Compare the values of V_1 and V_2 with those you measured for each circuit. Why might you expect the experimental values to be different?

For your records:

- There is a straightforward way to view these results:
 - The voltage from the power supply is shared between the resistors, so that $V_1 + V_2 = V_S$.
 - The bigger the resistor, the bigger its share of the voltage.
- In the first circuit, $R_1 = R_2 = 10k\Omega$ so $V_1 = V_2 = \frac{1}{2}V_S$.
- In the second and third circuits, $R_2 = 10 \times R_1$, and so $V_2 = 10 \times V_1$.
- The second and third circuits produce the same result, but the current is different.
- Sometimes it is best to use big resistor values, to reduce battery drain and power dissipation.
- However, using lower resistor values allows us to draw more current from the voltage divider circuit without really affecting voltages V_1 and V_2 .

Worksheet 7

Current dividers

Intermediate electrical and electronic principles

Voltage dividers use resistors connected in **series** to split a voltage into calculable fractions.

Current dividers use resistors connected in **parallel** to set up known fractions of current.

Current dividers are used in ammeters. A known fraction of the total current passes through the meter and is measured. From that the total current is calculated.



Over to you:

- Connect two $10k\Omega$ resistors in parallel, as shown in the circuit diagram.
- Set the power supply to give a 6V output.
- Remove the connecting link at **A**. Connect a multimeter, on the 2mA DC range, to measure the current, I_1 , at **A** (the total current leaving the power supply.) Record the value in the table.
- Remove the multimeter and replace link **A**.
- Measure the current at **B**, I_2 , in the same way, and record the result in the table.
- Set up the multimeter to read DC voltages of about 10V, and connect it across the power supply to read V_s . Record it in the table.
- Next, set the power supply to 9V, and repeat the measurements. Record them in the table.

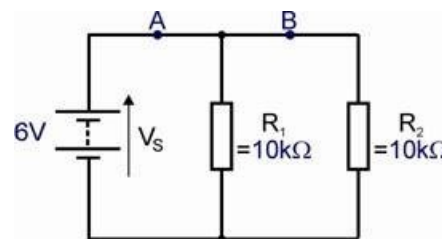

$R_1 = 10k\Omega, R_2 = 10k\Omega$		
Power supply voltage		
Current at point A , I_1 , in mA		
Current at point B , I_2 , in mA		

- Lastly, swap resistor R_1 for a $1k\Omega$ resistor. Change the multimeter range to 10mA.
- Repeat the process, with the power supply still set to 9V, and record the results in a second table.

$R_1 = 1k\Omega, R_2 = 10k\Omega$		
Power supply voltage		
Current at point A , I_1 , in mA		
Current at point B , I_2 , in mA		

Worksheet 7

Current dividers

Intermediate electrical and electronic principles

So what?

First of all, the theoretical behaviour -

- The voltage across resistor $R_1 = V_S$, and so:

$$V_S = I_1 \times R_1$$

- Similarly, $V_S = I_2 \times R_2$
which means that:

$$I_1 \times R_1 = I_2 \times R_2$$

or: $I_1 = I_2 \times (R_2 / R_1)$

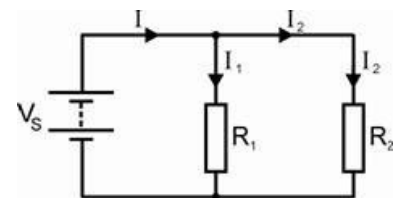

The current I from the power supply splits into I_1 and I_2 at the junction.

In other words: $I = I_1 + I_2$

Using the equation for I_1 given above: $I = I_2 \times (R_2 / R_1) + I_2$
 $= I_2 (1 + R_2 / R_1)$

Re-arranging this gives $I_2 = I \times (\frac{R_1}{R_1 + R_2})$

This can be used to calculate the current I_2 flowing in the branch of the circuit.

- Use this formula to calculate I_2 in the three cases you looked at in your investigation. Write your results in the following table:

Circuit	I_2 in mA
$R_1 = 10k\Omega, R_2 = 10k\Omega, \text{Power supply set to } 6V$	
$R_1 = 10k\Omega, R_2 = 10k\Omega, \text{Power supply set to } 9V$	
$R_1 = 1k\Omega, R_2 = 10k\Omega, \text{Power supply set to } 9V$	

- Compare the calculated values of I_2 with those you measured for each circuit. Again, why might you expect the experimental value to be different to the theoretical one?

For your records:

- As with voltage dividers, there is a straightforward way to view these results:
 - The current from the power supply is shared between the resistors, so that $I = I_1 + I_2$
 - The *bigger* the resistor, the *smaller* its share of the current.
- In the first and second circuits, $R_1 = R_2 = 10k\Omega$ so $I_1 = I_2 = \frac{1}{2} I$.
- In the third circuit, $R_2 = 10 \times R_1$, and so $I_1 = 10 \times I_2$.

Worksheet 8

Using Kirchhoff's Laws

Intermediate electrical and electronic principles

- **Kirchhoff's Current Law** - 'What flows in must flow out'

The algebraic sum of all currents at any junction is zero.

In other words, $I_1 = I_2 + I_3$

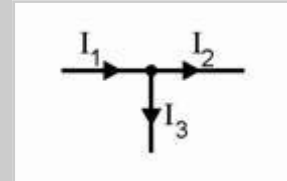

- **Kirchhoff's Voltage Law** -

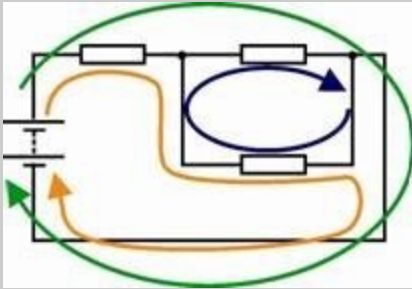

Around any loop in the circuit, the algebraic sum of voltages is zero. The expression 'algebraic sum' simply means that we must take the direction of current flow into account.

There are three loops in the circuit you will investigate. These are shown in different colours in the diagram.

Over to you:

- Connect a 1kΩ, a 2.2kΩ and a 10kΩ resistor, as shown in the circuit diagram.

- Set the power supply to give a 9V output.

- Remove the connecting link at **P**.

Connect a multimeter, on the 10mA DC range, to measure the current at **P**, (the total current leaving the power supply,) and record it in the table.

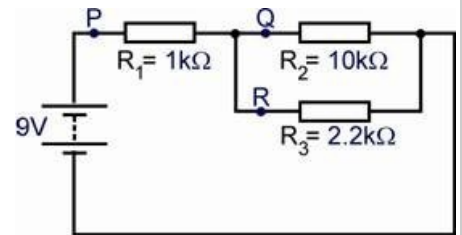

- Remove the multimeter and replace link **P**.

- Measure the current at **Q** and then **R** in the same way, and record the results in the table.

- Set up the multimeter to read DC voltages of about 10V, and use it to measure the voltages across the three resistors. Record them in the table.

Measurement	Value
Current at point P in mA	
Current at point Q in mA	
Current at point R in mA	
Voltage across R₁	
Voltage across R₂	
Voltage across R₃	

- Next, we are going to analyse these results using Kirchhoff's Current and Voltage Laws.

Worksheet 8

Using Kirchhoff's Laws

Intermediate electrical and electronic principles

So what?

- Kirchhoff's current law gives us the relationship:

$$I_1 = I_2 + I_3$$

- Now apply Kirchhoff's voltage law to each of the three loops.

The **green** loop: $9 = V_1 + V_2$ equation 1

The **orange** loop: $9 = V_1 + V_3$ equation 2

The **blue** loop: $0 = V_2 + V_3$

- Ohm's law gives us the relationships:

$$V_1 = I_1 \times R_1 = (I_2 + I_3) \times R_1$$

$$V_2 = I_2 \times R_2$$

$$V_3 = I_3 \times R_3$$

- Inserting the values of the resistors (in kΩ) gives:

$$V_1 = (I_2 + I_3) \times 1 = (I_2 + I_3)$$

$$V_2 = I_2 \times 10$$

$$V_3 = I_3 \times 2.2$$

- Using these, **equation 1** becomes $9 = (I_2 + I_3) + (10 \times I_2)$

or $9 = 11I_2 + I_3$

which means that $I_3 = 9 - 11I_2$

and **equation 2** becomes $9 = (I_2 + I_3) + (2.2 \times I_3)$

or $9 = I_2 + 3.2I_3$

Inserting the value of I_3 gives $9 = I_2 + 3.2(9 - 11I_2)$

so $(35.2 - 1)I_2 = 28.8 - 9$

which gives $I_2 = \mathbf{0.58 \text{ mA}}$

Substituting this in earlier equations $I_3 = 9 - 11I_2 = 9 - 11 \times 0.58 = \mathbf{2.63 \text{ mA}}$

and so $I_1 = 0.58 + 2.63 = \mathbf{3.21 \text{ mA}}$

In turn, these values give $V_1 = 3.21 \times 1 = 3.2 \text{ V}$

$$V_2 = 0.58 \times 10 = 5.8 \text{ V}$$

$$V_3 = 2.63 \times 2.2 = 5.8 \text{ V (not surprisingly!)}$$

- Check your measured values against these results!

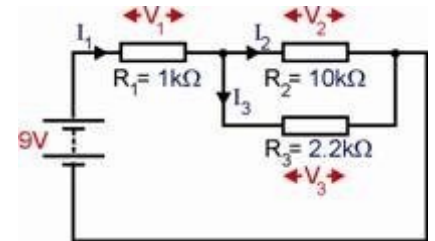

w8d

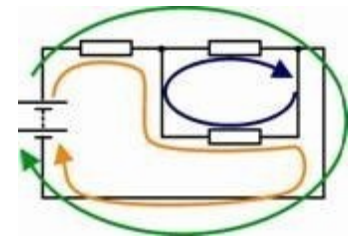

w8e

For your records:

- Kirchhoff's Current Law - 'What flows in must flow out'
The algebraic sum of all currents at any junction is zero.
- Kirchhoff's Voltage Law -
Around any loop in the circuit, the algebraic sum of voltages is zero.

Worksheet 9

Power in DC circuits

Intermediate electrical and electronic principles

Electrical power is vital to the operation of many complex systems. An aircraft, for example, would not be able to fly without electricity.

The ability to generate and make efficient use of electrical power is central in the modern world. As a result, you need a sound grasp of electrical power and energy conversion.

This worksheet provides a useful introduction to this topic.

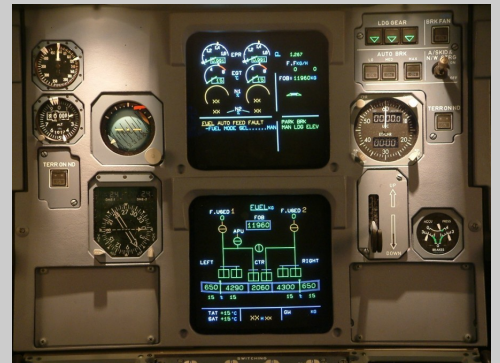

Over to you:

- Set up each the circuit in turn .
- For each bulb, measure:
 - the current through it,
 - the voltage across it.

(First, decide where to connect the ammeter and voltmeter!)

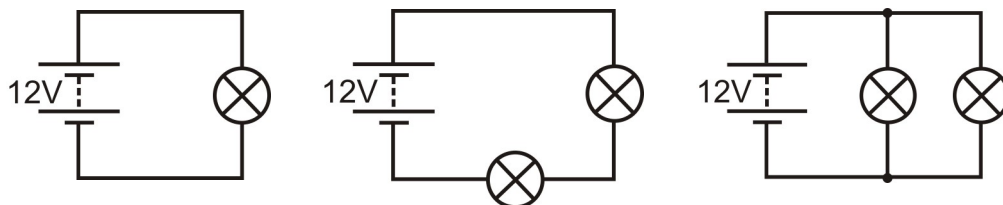

A few relationships that you need to know:

A reminder:

Electric current is a measure of how many electrons are passing per second.

Voltage is a measure of the energy the electrons gain or lose on passing through a component.

Fact 1: **Number of coulombs $Q = \text{Current } I \times \text{time } t$**

(Common sense - current measures how many electrons pass per second, so to find out how many have passed in 10 seconds, for example, you simply multiply the current by 10!)

Fact 2: **One volt means one joule of energy given to or lost by one coulomb of charge.**

(A 12V battery gives each coulomb of charge that passes through it 12J of energy. If the voltage dropped across a resistor is 2V, every coulomb that passes through it loses 2J of energy (i.e. converts 2J to heat energy. It's the electrons struggling to squeeze past the atoms in the resistor - it makes them hot!)

Fact 3: **Power is the rate at which energy is converted.**

(So - a power rating of one watt of means that one joule of energy is converted from one form to another every second. The old style of domestic light bulbs had power ratings of about 60W. Newer energy-saving types have a rating of 15W for the same brightness, because they convert waste less electrical energy as heat!)

Worksheet 9

Power in DC circuits

Intermediate electrical and electronic principles

So what?

Formula juggling - ignore all but the result if you wish:

$$\begin{array}{llll}
 P = E / t & \text{from fact 3} & \text{and } E = Q \times V & \text{from fact 2} & \text{so } P = Q \times V / t \\
 \text{but } Q = I \times t & \text{from fact 1} & \text{so} & P = I \times t \times V / t & \\
 \text{or, cancelling out the 't'} & & \text{Result} & \mathbf{P = I \times V} &
 \end{array}$$

The cast:

P = power in watts E = energy converted in joules Q = charge in coulombs
 I = current in amps V = voltage dropped in volts! t = time energy conversion took in seconds

• Use your results to answer the following:

- Calculate:
 - the power dissipated in each bulb (using the formula $P = I \times V$)
 - how long it takes each bulb to take 1J of energy from the electrons;
 - how much energy (in joules) the power supply is losing each second.
- Each of the three circuits that you investigated transferred energy at different rates. The amount of energy transferred depends not only on the number of lamps but also on the way they are connected. Think about the energy dissipated in each of the three circuits. Which circuit will transfers the least energy and which the most in a given time? Explain to your colleague why this is.
- Which battery will 'go flat' first?
Explain your answer in terms of the amount of energy converted.

For your records:

- Power is the rate at which energy is being used.
- When a component has a voltage V across it, and a current I flowing through it, it is converting energy from one form to another at a rate given by the power formula

$$P = I \times V.$$

Questions:

1. A DC power unit supplies 28V to two parallel loads, each rated at 288W, for 10 minutes. What current is supplied to each load?
What energy is supplied by the power unit in that 10 minutes?
2. The battery in an emergency radio beacon can supply 480kJ of energy. The battery is rated at 12V 1A. For how many hours will the beacon operate?

Answers are provided on page 70.

Worksheet 10

Electrostatics and capacitors

Intermediate electrical and electronic principles

Static electricity can be produced by friction (for example, rubbing a balloon on a woollen sweater).

Bodies charged by this method have either positive or negative polarity, depending on whether a deficit or excess of charge-carrying electrons is present.

Bodies can remain in this state for some time. Stray static charge like this cause electrical noise and interference to avionic and communications equipment . Special measures, such as static discharging wicks - are used to avoid the build-up of charge on aircraft.

Capacitors, extremely useful electrical components, provide us with a means of accumulating and storing electric charge. A simple capacitor consists of two metal plates separated by an insulating dielectric, such as polyester film. The charge present is the product



w10a

Over to you (optional investigation):

- Make your own capacitor with a square of thin card between two square aluminium plates. Keep it clamped together by placing it between heavy glass plates with a heavy object on top.
- Measure the capacitance of your capacitor using a digital multimeter switched to the 2nF range.
- Increase the separation of the plates by adding extra pieces of card (up to six).
- Each time, measure and record the capacitance.

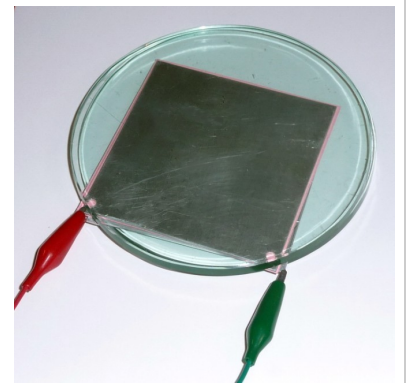

w10b

Thickness of card	1	2	3	4	5	6
C in nF						

- Next change the amount by which the plates overlap (whilst keeping the plates parallel). Mark lines on the capacitor at 75%, 50%, 37.5%, 25% and 12.5% of the surface and for each overlap, measure and record the capacitance in the table.

Area of overlap	100% (A)	75% (3A/4)	50% (A/2)	37.5% (3A/8)	25% (A/4)	12.5% (A/8)
C in nF						

Worksheet 10

Electrostatics and capacitors

Intermediate electrical and electronic principles

So what?

Use your results to:

- Plot a graph showing how the capacitance changes with plate separation.
- Plot a graph showing how capacitance changes with the overlapping area of the plates.
- What conclusions can you draw from the first graph?
- What conclusions can you draw from the second graph?

For your records:

- Increasing the separation of the plates reduces the capacitance.
More precisely, capacitance is inversely proportional to the plate separation.
- Increasing the overlap of the plates increases the capacitance.
More precisely, capacitance is directly proportional to the plate area.
- Combining these results we can arrive at the important relationship:

$$C \propto \frac{A}{d} = k \frac{A}{d} = \frac{\epsilon_0 \epsilon_r A}{d}$$

where:

C = capacitance;

A = plate area;

d = plate separation;

ϵ_0 = permittivity of free space;

ϵ_r = relative permittivity of the dielectric material (insulator).

Worksheet 11

Capacitor charge and discharge

Intermediate electrical and electronic principles

Capacitors provide a means of storing electric charge, acting as a reservoir for electrical energy. Charge can be transferred to a capacitor by connecting it to a power supply or a battery.

When the capacitor discharges, the stored energy is released, usually as heat. Later, the capacitor can be recharged. The stored energy is then replenished.

In this worksheet, you investigate capacitor charge and discharge.



w11a

Over to you:

Charging a capacitor:

- Build the circuit shown opposite, using values $R = 10\text{k}\Omega$ and $C = 1,000\mu\text{F}$.
- Make sure that the DC power supply is set to 9V.
- Use a multimeter, on the 20V DC scale to measure the voltage across the capacitor.
- Press and hold down switch S to discharge the capacitor fully.
- Release S so that the capacitor begins to charge, and measure and record the capacitor voltage every 10 seconds.
- Repeat this process using values of $C = 2,200\mu\text{F}$ and $R = 10\text{k}\Omega$, and then $C = 1,000\mu\text{F}$ with $R = 22\text{k}\Omega$. You now have three sets of readings, set out in three tables like the one below:

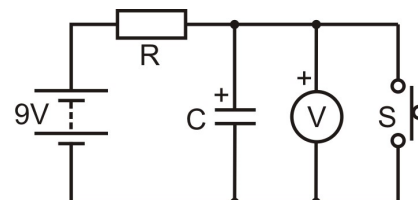

w11b

	R = k Ω , C = μF												
Time in s	0	10	20	30	40	50	60	70	80	90	100	110	120
Capacitor voltage in V													

Discharging a capacitor:

- Build the circuit shown opposite, with $R = 10\text{k}\Omega$ and $C = 1,000\mu\text{F}$.
- Again, make sure that the power supply is set to 9V DC and that the multimeter is on the 20V DC range.
- Press and hold down switch S to charge the capacitor fully. The charge will build up rapidly as there is no resistance to limit the charging current.
- Release S so that the capacitor begins to discharge and record the voltage every 10 seconds in a table like the one above.
- Repeat the same process for values of $C = 2,200\mu\text{F}$ and $R = 10\text{k}\Omega$, and then $C = 1,000\mu\text{F}$ with $R = 22\text{k}\Omega$. You should once again have three sets of readings set out in three tables.

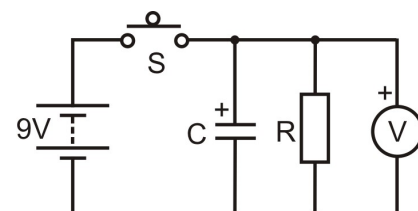

w11c

Worksheet 11

Capacitor charge and discharge

Intermediate electrical and electronic principles

So what?

- Use your results to:
 - plot three graphs showing how the capacitors charge, when connected to series resistors, (over the period from 0 to 120s.)
 - plot three graphs showing the discharge of capacitors through 'shunt' resistors, (again over the period from 0 to 120s.)
- The diagrams show typical shapes for these graphs. Guided by your experimental points, draw smooth curves for each graph.

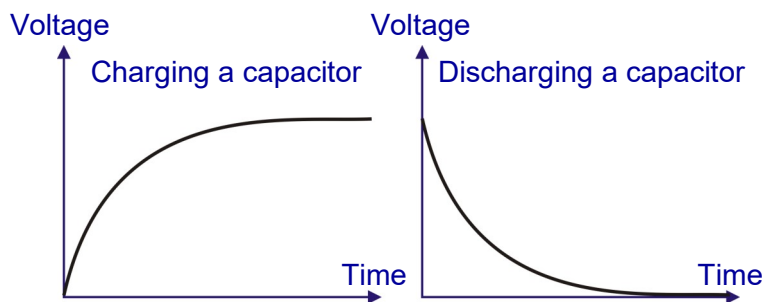

- Take a close look at your graphs. Does the capacitor ever completely charge or discharge?
- What effect do the values chosen for C and R have on the rate at which the capacitor charges or discharges?
- For each charging graph, find the time it takes for the capacitor voltage to reach 63% of its final value. Compare this with the corresponding time constant ($= R \times C$, where R is in $M\Omega$ and C in μF .)
- For each discharging graph, find the time it takes for the capacitor voltage to fall to 37% of its initial value. Once again, compare this time value with the corresponding time constant).
- The charge and discharge curves show **exponential growth** and **exponential decay** respectively. Find out as much as you can about the exponential constant, e.

For your records:

- A capacitor charges faster initially, as a larger charging current flows, and then the rate of charging slows down. The shape of the charging curve is an example of exponential growth.
- When a capacitor discharges, the voltage across it falls rapidly to begin with, and then falls more slowly. This is an example of exponential decay.
- The rate of change of voltage for both charge and discharge is governed by the time constant for the R-C network. The time constant **T** is calculated using the formula:

$$T = R \times C$$

and it has units of seconds if **R** is in Ω and **C** in F,
or if **R** is in $M\Omega$ when **C** is in μF .

Worksheet 12

Electromagnetism

Intermediate electrical and electronic principles

Many electrical components, such as the generator shown here, are based on the application of electromagnetism.

To generate an emf, you need a magnetic field, a wire conductor and some relative movement as you will see from this investigation.

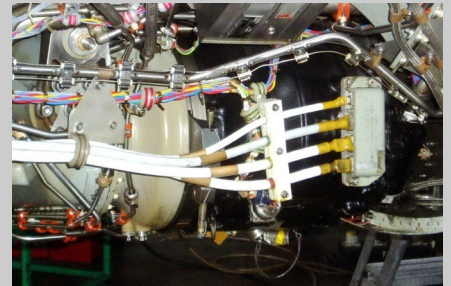

w12a

Over to you:

- Set up the arrangement shown in the diagram.
- The amount of electricity generated will be tiny.
We can observe it using:
 - the Locktronics milliammeter module, connected as shown;
 - a multimeter, connected to points **X** and **Y**;
 - an oscilloscope, connected to points **X** and **Y**.
- If using the multimeter, set it to its most sensitive DC current scale. However, this *samples* the input signal periodically. The meter may miss an event that takes place in between samples so you may need several attempts to see convincing results.
- For the oscilloscope, suitable settings are given at the bottom of the page.
- Move the magnet into the coil as fast as you can.
Watch what happens to the output, as you do so.
- Next reverse the direction of motion, and pull the magnet out, watching what happens as you do so.

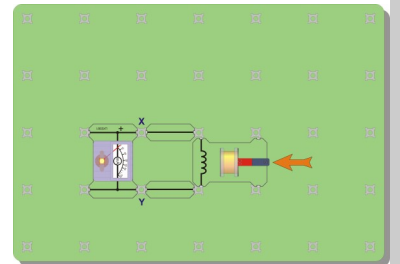

w12b

w12c

Optional extension:

- Investigate the effect of speed of movement on the emf produced.

Typical oscilloscope settings:

Timebase	1s/div (X multiplier x1)		
Voltage range	Input A	±200mV DC (Y multiplier x1)	
	Input B	Off	
Trigger mode	Auto	Trigger channel	Ch.A
Trigger direction	Rising	Trigger threshold	10mV

Worksheet 12

Electromagnetism

Intermediate electrical and electronic principles

So what?

From the results, the generated current and voltage have:

- a **magnitude** that depends on the speed of movement;
- a **polarity** that depends on the direction of motion.

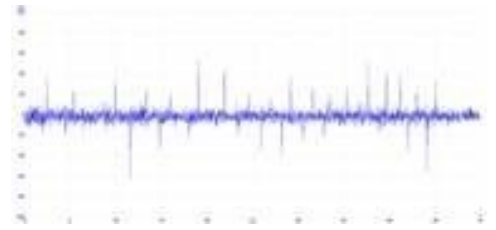

w12d

Typical results for the oscilloscope are shown here. Inserting the magnet generates a pulse of current in one direction, and withdrawing it produces a pulse of opposite polarity. (Experiment with other time base settings to try to get better results.)

Here's the underlying physics:

- When the wire moves at right-angles to the magnetic field, the electrons move with it.
- Whenever electrons move, they generate a magnetic field.
- This interacts with the field of the magnet, exerting a force on the electrons at right-angles to the direction of motion and to the magnetic field.
- This force pushes electrons along the wire, generating a voltage and a current if there is an electrical circuit.
- Using a coil of wire increases the size of voltage and current generated because each wire turn in it is moving inside the magnetic field, and so has electricity generated in it. The effects of all the turns add together, increasing the amount of electricity generated.

Fleming's Right-hand Rule:

Fleming devised a painful way of predicting the direction of the generated current .

Use your **right**-hand to produce the gesture shown in the picture. Fore finger, centre finger and thumb are all at right-angles to each other!

When the **F**ore finger points in the direction of the magnetic **F**ield (from North pole to South pole,) and the **th**u**M**b points in the direction of the **M**otion, the **C**entre finger points in the direction of the resulting **C**urrent. This is also known as the *dynamo rule*.

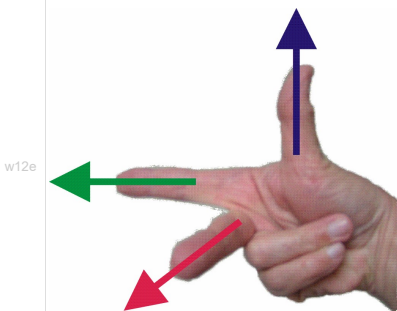

w12e

Optional extension:

If you have other coils available, and other magnets, you could show that the magnitude also depends on the number of turns of wire in the coil and the strength of the magnetic field.

For your records:

Use the results of the investigation to answer the following questions:

- What factors determine the emf generated?
- How can you predict the polarity of the emf generated?

Worksheet 13

Inductors and inductance

Intermediate electrical and electronic principles

A current flowing in a conductor creates a magnetic field in the space around it. This can be intensified by winding the conductor into a coil and then inserting a core of a material such as iron, steel or ferrite, a ceramic material containing iron oxide.

When a changing current passes through an inductor, an induced emf appears across its terminals. This opposes the change that created it, which explains why larger inductors are often referred to as **chokes**.

Inductors are used in many applications, from filters to fluorescent lighting and ignition units.

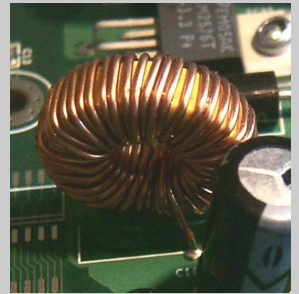

w13a

Over to you:

- Build the circuit shown.
The push-to-make switch, S is connected in series with R, a current-limiting resistor. The inductor, L is the primary of the 2:1 transformer, (the secondary winding is left disconnected).
- Set the power supply to 12V DC.
- Connect an oscilloscope to display the voltage drop across the inductor. Make sure the leads are connected with the polarity shown on the diagram. Typical settings for the oscilloscope are given in the next section.
- Switch on the DC power supply and then press, and hold the switch closed so that current flows through the inductor.
- Keep the switch closed for a few seconds then release it and observe the result on the oscilloscope . You should see a sudden, very large negative voltage spike.
- You may have to repeat this step several times to obtain a satisfactory display

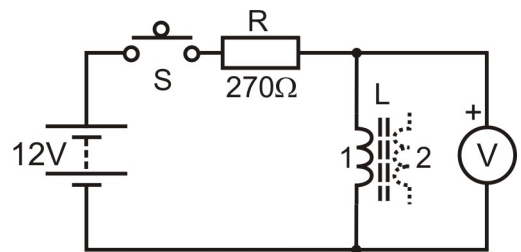

w13b

Typical oscilloscope settings:

Timebase 1 ms/div (X multiplier x1)

Voltage range Input A ±20 V DC (Y multiplier x1)

Input B Off

Trigger mode Repeat **Trigger channel** Ch.A

Trigger direction Falling **Trigger threshold** 1000 mV

Worksheet 13

Inductors and inductance

Intermediate electrical and electronic principles

So what?

The trace shows a typical display produced when the switch is released.

It shows the large negative spike generated as the magnetic field in the inductor suddenly collapses, when the current is interrupted.

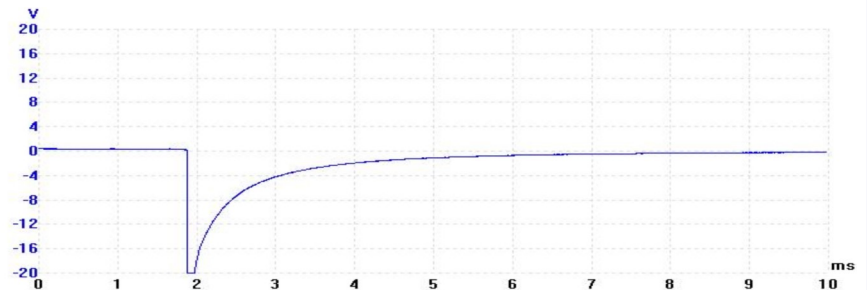

Here's the physics:

- When the switch is closed, a steady current flows in the inductor and produces a steady magnetic field in its core.
- When the current is interrupted by opening the switch, the magnetic field collapses rapidly because there's nothing to maintain it.
- When the field collapses through the turns of the inductor coil, a voltage is generated across the terminals of the inductor. This can be many times greater than the supply voltage.
- The induced voltage is negative. In other words it opposes the original direction of current flow, and as a result it is called a *back emf*.
- A large back emf. can cause considerable damage such as arcing at switch or relay contacts and destruction of low-voltage electronic components.

For your records:

Back emf:

- appears whenever current is suddenly removed from an inductor.
- opposes the original current flow.
- can be very large and many times greater than the supply voltage.
- We often take precautions to limit the back emf generated when an inductive component (such as a relay coil) is switched on and off.

Later, you see that this can be achieved easily using a diode, connected with reverse bias, in parallel with the inductive component.

Worksheet 14

AC measurements

Intermediate electrical and electronic principles



The ability to make accurate measurements of alternating current and voltage is an important skill. In reality, AC measurements are not quite so easy to make as DC.

First of all, here's a brief introduction to some of the quantities and terminology that you will need to get to grips with:

AC voltage and current

When measuring alternating voltage and current, we usually use *root-mean-square* (RMS) values. These are the effective value of an alternating current. They are the DC equivalents that would produce the same heating effect if applied to a resistor.

It is sometimes useful to use the *peak* or *peak-to-peak* value of an AC waveform as they are easy to measure using an oscilloscope (see the picture).

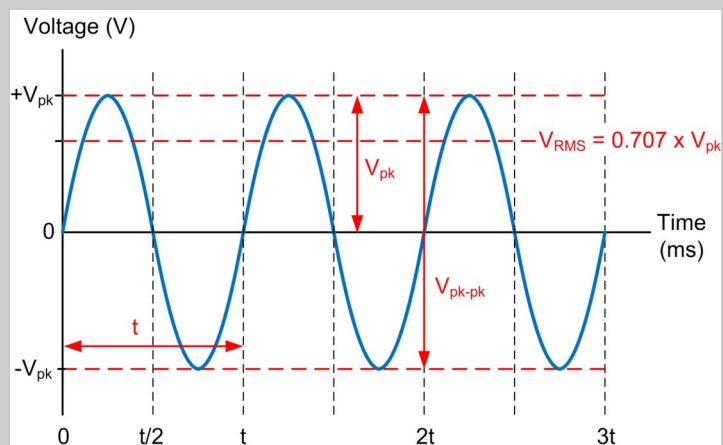

Frequency

The frequency of a repetitive waveform is the number of cycles of the waveform which occur in one second. Frequency is expressed in hertz, (Hz), and a frequency of 1Hz is equivalent to one cycle per second. Hence, a signal frequency of 400Hz means that 400 cycles of it occur every second.

Periodic time

The periodic time (or period) of a signal is the time taken for one complete cycle of the wave. The relationship between periodic time, t , (in s) and frequency, f , (in Hz) is:

$$t = 1 / f \text{ or } f = 1 / t$$

For example, the periodic time of a 400Hz AC signal is 2.5ms.

Waveforms

Waveforms show us how voltage or current signals vary with time. Common types of waveform include sine (or sinusoidal), square, triangle, ramp (which may be either positive or negative going), and pulse. In this module we are concerned only with the most basic of waveforms, the sine wave.

Waveforms are viewed and measured using an oscilloscope, either a conventional type or a virtual instrument (like Picoscope).

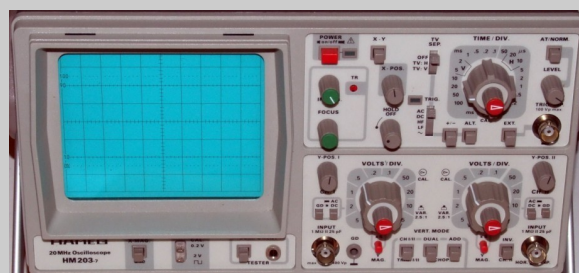

Worksheet 14

AC measurements

Intermediate electrical and electronic principles

Over to you:

- Connect an oscilloscope to display the output of an audio frequency signal generator. (Typical oscilloscope settings are given at the bottom of the page.)
- Adjust the signal generator to produce a sine wave output at 100Hz. and set the amplitude of the signal so that the display on the oscilloscope is exactly 2V peak-peak.
- Sketch the oscilloscope display on the graph paper and make sure that you label the voltage and time axes.
- Use the X-axis time scale on the oscilloscope to measure accurately the time for one complete cycle (i.e. the periodic time). Show this in the table.
- Set the signal generator to 200Hz, 400Hz, 600Hz, 800Hz and finally 1,000Hz and at each frequency measure and record the period time in the table.
- Use the data in the table to plot a graph of periodic time against frequency.
Use this to verify the relationship $f = 1/t$.

Frequency (Hz)	Periodic time (ms)
100	
200	
400	
600	
800	
1000	

For your records:

- Write a short description of the following AC terms:
 - amplitude;
 - frequency;
 - period.
- The rms (root-mean-square) value of a sinusoidal AC signal gives the equivalent DC voltage which has the same effect. To replace an AC power source, which has a rms voltage of 12V, you could use a 12V DC source instead.
- The rms and peak values of a sinusoidal AC signal are related by the relationship:

$$\text{Peak value} = \text{rms value} \times \sqrt{2}$$

Typical oscilloscope settings:

Timebase - 1ms/div (X multiplier x1)

Voltage range - Input A - $\pm 5V$ DC (Y multiplier x1) Input B - Off

Trigger Mode - Auto **Trigger Channel** - Ch.A

Trigger Direction - Rising **Trigger Threshold** - 10mV

Worksheet 15

AC and inductors

Intermediate electrical and electronic principles

w15a



Resistors oppose electric currents. Inductors oppose *changes* to electric currents, but the mechanism is different. An electric current flowing in the inductor, sets up a magnetic field. Increasing the current increases the magnetic field, and that takes energy from the current, opposing the increase. Reducing the current reduces the magnetic field, and that releases energy, which tries to maintain the current.

Inductors behave rather like flywheels on a rotating shaft. Their angular momentum tries to keep the shaft rotating at the same speed. When the shaft starts to slow down, the energy stored in the flywheel tries to keep it going. When the shaft tries to speed up, the flywheel requires energy to speed it up, and so the flywheel seems to resist the change.

Over to you:

- Connect a 47mH inductor in series with a signal generator, as shown in the circuit diagram.
- Use enough connecting links so that the current can be measured at point **A**. The photograph shows one way to do this.
- Set the signal generator to output an AC voltage at a frequency of 50Hz.
- Remove the connecting link at **A**, and connect a multimeter, set to read up to 20mA **AC**, in its place.
- In the table, record the current flowing at point **A**.
- Remove the multimeter and replace link **A**.
- Set up the multimeter to read **AC** voltages of up to 20V and connect it in parallel with the inductor.
- Record the voltage in the table.
- Now change the signal generator frequency to 100Hz and repeat the measurements. Record them in the table.
- Do the same for frequencies of 500Hz and 1kHz (1,000Hz). Again, record the measurements in the table.

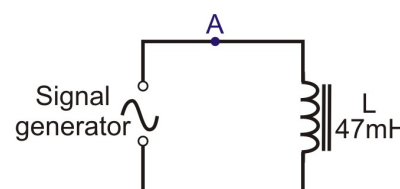

w15b



w15c

Frequency	Current I	Voltage V
50 Hz		
100 Hz		
500 Hz		
1 kHz		

Worksheet 15

AC and inductors

Intermediate electrical and electronic principles

So what?

- Resistors behave in a linear way. From Ohm's Law we know that if you double the current through the resistor, you double the voltage dropped across it, and so on. The ratio of voltage to current is called resistance.
- Inductors are more complicated. If you double the *rate of change* of current through the inductor, you double the voltage dropped across it, and so on. The ratio of voltage to rate of change of current is called **inductance**.
- The higher the frequency of the AC, the faster the current changes, and so the greater the voltage drop across the inductor. In other words, the voltage dropped depends on the frequency of the AC supply. This is **not** the case with pure resistors, where frequency has no effect.
- We describe this behaviour in terms of the **(inductive) reactance, X_L** , defined, in the same way as resistance, as $X_L = V / I$. As a result, the units of reactance are ohms.
- The inductive reactance measures the opposition of the inductor to changing current. The higher the frequency, f , the greater the change in current. In fact, the formula for inductive reactance is: $X_L = 2 \pi f L$
- Using your measurements, calculate the X_L , from the formula: $X_L = V / I$ and compare that with the value calculated using $X_L = 2 \pi f L$ where $L = 47\text{mH}$.
- Carry out these calculations and complete the following table with your results:

Frequency	Inductive reactance $X_L = V / I$	Inductive reactance $X_L = 2 \pi f L$
50Hz		
100Hz		
500Hz		
1kHz		

For your records:

- The opposition of an inductor to changing currents is called inductive reactance, X_L , given by the formula: $X_L = 2 \pi f L$ where f is the AC frequency, and L is the inductance of the inductor.
- It can also be obtained from the formula $X_L = V / I$, where V and I are rms voltage and current respectively.
- Inductance is measured in a unit called the Henry, (H) and reactance in ohms.
- Complete the following:
 When the AC frequency is doubled, the inductive reactance is
 When the AC frequency is halved, the inductive reactance is

Worksheet 16

AC and capacitors

Intermediate electrical and electronic principles

w16a



An electric current sets up a **magnetic** field inside an inductor. This then oppose changes to electric *currents*. An electric current sets up an **electric** field across the plates of a capacitor. This opposes changes to the *voltage* applied to the capacitor.

Before the voltage can increase, electrons must flow onto the plates of the capacitor, increasing the electric field. This requires energy.

When the voltage starts to decrease, electrons flow off the plates, reducing the electric field. These electrons try to maintain the voltage across the capacitor's plates.

Capacitors behave rather like buckets in a water circuit. They must fill up before any water flows anywhere else in the circuit. When the flow of water starts to fall, excess water flows from the bucket, trying to maintain the flow.

Over to you:

- Connect a $1\mu\text{F}$ capacitor in series with the signal generator, as shown in the circuit diagram.
- Use enough connecting links so that the current can be measured at point **A**.
- Set the signal generator to output an AC voltage at a frequency of 50Hz.
- Remove the connecting link at **A**, and connect a multimeter, set to read up to 20mA AC, in its place.
- Record the current flowing at point **A** in the table.
- Remove the multimeter and replace link **A**.
- Set up the multimeter to read AC voltages of up to 20V and connect it in parallel with the capacitor.
- Record the voltage in the table.
- Now change the signal generator frequency to 100Hz and repeat the measurements. Record them in the table.
- Do the same for frequencies of 500Hz and 1kHz (1,000Hz). Again, record the measurements in the table.

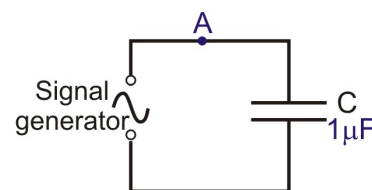

w16b



w16c

Frequency	Current I	Voltage V
50 Hz		
100 Hz		
500 Hz		
1 kHz		

Worksheet 16

AC and capacitors

Intermediate electrical and electronic principles

So what?

- For resistors, double the *current* through the resistor and you double the voltage dropped across it, and so on. For inductors, double the *rate of change of current* through the inductor and you double the voltage dropped across it, and so on.
- Capacitors oppose changing *voltage*. The faster the *rate of change of voltage*, the greater the current needed to charge or discharge the capacitor. The higher the frequency of the AC, the faster the *voltage* changes, and so the greater the current flowing in the circuit. In other words, the current depends on the frequency of the AC supply.
- We describe this behaviour in terms of the **capacitive reactance**, X_C , defined, in the same way as resistance, as $X_C = V / I$. As before, the units of reactance are ohms.
- Capacitive reactance measures the opposition of the capacitor to changing current. The formula for capacitive reactance is: $X_C = 1 / (2 \pi f C)$
- Capacitors are mirror images of inductors. As the frequency of the AC supply increases, an inductor offers more opposition, (inductive reactance increases, and current decreases) whereas a capacitor offers less opposition, (capacitive reactance and current both decrease).
- Using your measurements, calculate the X_C , using both :

$$X_C = V / I \quad \text{and} \quad X_C = 1 / (2 \pi f C) \quad \text{where } C = 1\mu\text{F}$$
- Carry out those calculations and complete the following table with your results:

Frequency	Capacitive reactance $X_C = V / I$	Capacitive reactance $X_C = 1 / (2 \pi f C)$
50Hz		
100Hz		
500Hz		
1kHz		

For your records:

- The opposition of a capacitor to changing voltage is called capacitive reactance, X_C , given by: $X_C = 1 / (2 \pi f C)$ where f is the frequency of the AC signal, and C is the capacitance.
- It can also be obtained from the formula $X_C = V / I$, where V and I are rms voltage and current respectively.
- Capacitance is measured in farads (F), though, in practice, this unit is too large. Most capacitors have values given in microfarads (μF).
- Complete the following:
 When the AC frequency is doubled, the capacitive reactance is
 When the AC frequency is halved, the capacitive reactance is

Worksheet 17

L-R series circuit

Intermediate electrical and electronic principles



When an inductor and a resistor are connected in series, the pair act as a voltage divider, but with an important difference - the way they share an AC voltage changes with frequency. The circuit is known as a series L-R circuit.

As it is a series circuit, the same current flows everywhere.

The opposition to the current comes in two forms, the resistance of the resistor, which is independent of frequency, and the reactance of the inductor, which increases as the frequency increases. Together, these combine to make what is known as the impedance of the circuit.

Over to you:

- Connect a 270Ω resistor, and a 47mH inductor in series with the signal generator, as shown in the circuit diagram.
- Use enough connecting links so that the current can be measured at point **A**.
- Set the signal generator to output an AC voltage at a frequency of 100Hz .
- Remove the link at **A**, and connect a multimeter, set to read up to 20mA AC , in its place.
- Record the current flowing at point **A** in the table.
- Remove the multimeter and replace link **A**.
- Set up the multimeter to read AC voltages of up to 20V . Connect it to measure the signal generator voltage, V_s , applied across the two components, and record it in the table.
- Measure the voltage V_L , across the inductor, and then the voltage V_R , across the resistor. Record these voltages in the table.
- Next, set the signal generator to a frequency of 1kHz . and repeat the measurements.
- Record them in the table.

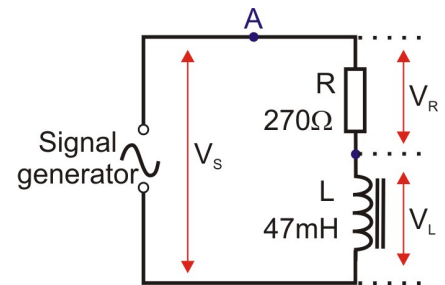

Measurement	AC frequency = 100Hz	AC frequency = 1kHz
Current at point A in mA		
Supply voltage V_s		
Voltage V_R across 270Ω resistor		
Voltage V_L across 47mH inductor		

Worksheet 17

L-R series circuit

Intermediate electrical and electronic principles

So what?

Theory allows us to calculate the quantities that you just measured. You can then compare the two results.

- The two effects limiting the current are:
 - the resistance of the resistor, $R = 270\Omega$;
 - the reactance X_L of the inductor.
 - At the first frequency, 100Hz:** $X_L = 2\pi fL = 2\pi(100) \times (47 \times 10^{-3}) = 29.5\Omega$
- The voltage across the resistor is in phase with the current through it. The voltage across the inductor is 90° ahead of the current. As a result, we cannot simply add together resistance and reactance. Instead, we combine them using the impedance formula which takes phase into account: $Z = (R^2 + (X_L - X_C)^2)^{1/2}$
- In this case, there is no capacitive reactance, and so:

$$Z = (R^2 + X_L^2)^{1/2} = ((270)^2 + (29.5)^2)^{1/2} = 271.61\Omega$$
- We can use this to calculate current, using the formula:

$$I = V_S / Z \quad \text{where } V_S = \text{AC signal generator voltage}$$
 - Use your measured value of V_S to calculate I .
 - Use this in the formula $V_R = I \times R$ to calculate the voltage V_R across the resistor.
 - Use it again in the formula $V_L = I \times X_L$ to calculate the voltage, V_L , across the inductor.
- Check these results against your measured values.
- At the second frequency, 1kHz:**
 - the share of the AC voltage changes - the higher frequency increases the reactance of the inductor to 10 times its earlier value, so $X_L = 295.3\Omega$, and the inductor takes a much bigger share of the AC voltage;
 - the output impedance of the signal generator may change;
- Repeat the calculations at 1kHz, and check your results against the measured values.

For your records:

- When the rms value of supply voltage is used, all currents and voltages will be rms.
- At frequency f , the reactance of the inductor is: $X_L = 2\pi fL$.
- The impedance of a L-R circuit is: $Z = (R^2 + X_L^2)^{1/2}$
- The rms current is given by: $I = V_S / Z$ where $V_S = \text{AC supply rms voltage}$.
- The resulting rms voltage across the resistor: $V_R = I \times R$
- The resulting rms voltage across the inductor: $V_L = I \times X_L$

Worksheet 18

C-R series circuit

Intermediate electrical and electronic principles

An inductor and a resistor, connected in series, act as a voltage divider, which depends on AC frequency. For the inductor, reactance increases as the frequency increases.

A similar effect is seen when a capacitor and resistor are connected in series, but with an important difference - the reactance of the capacitor decreases as the frequency increases.

As before, since it is a series circuit, the same current flows in all parts of the circuit.

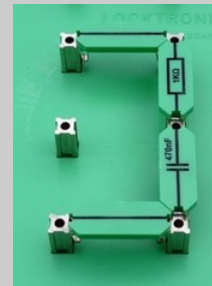

Over to you:

- Connect a 270Ω resistor, and a 1μF capacitor in series with the signal generator, as shown in the circuit diagram.
- Use enough connecting links so that the current can be measured at point **A**.
- Set the signal generator to output a voltage with a frequency of 100Hz.
- Remove the connecting link at **A**, and connect a multimeter, set to read up to 20mA AC, in its place. Record the current flowing at point **A** in the table.
- Remove the multimeter and replace link **A**.
- Set up the multimeter to read AC voltages of up to 20V. Connect it to measure the signal generator output voltage, V_s , applied across the two components, and record it in the table.
- Measure the voltage V_c , across the capacitor, and then the voltage V_r , across the resistor. Record these voltages in the table.
- Next, set the signal generator to a frequency of 1kHz., repeat the measurements and record them in the table.

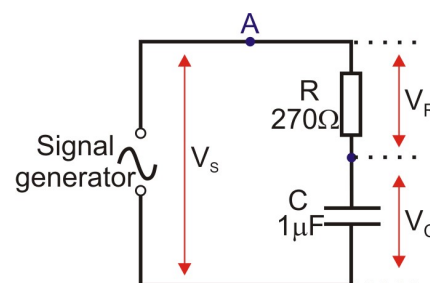

Measurement	AC frequency = 100Hz	AC frequency = 1kHz
Current at point A in mA		
Voltage V_R across R		
Voltage V_C across C		

Worksheet 18

C-R series circuit

Intermediate electrical and electronic principles

So what?

Once again, theory allows us to calculate the quantities that you just measured, and then you can then compare the results.

- The two effects limiting the current are:
 - the resistance of the resistor, $R = 270\Omega$;
 - the reactance X_C of the capacitor:
 - **At the first frequency, 100Hz:** $X_C = 1 / (2 \pi f C) = 1 / (2 \pi (100) \times (1 \times 10^{-6})) = 1591.5\Omega$
- Voltage and current are in phase in the resistor. There is a phase lag of 90° between voltage and current in the capacitor. Again, the formula for impedance, Z , takes this phase shift into account. In this case, there is no inductive reactance, and so:

using $Z = (R^2 + (X_L - X_C)^2)^{1/2} = (R^2 + X_C^2)^{1/2}$
 $= ((270)^2 + (1591.5)^2)^{1/2} = 1614.3\Omega$
- We can use this value of impedance to calculate the current, using the formula:

$$I = V_S / Z \quad \text{where } V_S = \text{AC signal generator voltage}$$
 - Use your measured value of V_S to calculate I .
 - Use this in the formula $V_R = I \times R$ to calculate the voltage V_R across the resistor.
 - Use it again in the formula $V_L = I \times X_C$ to calculate the voltage, V_C , across the capacitor.
- Check these results against your measured values.
- **At the second frequency, 1kHz:**
 - again, the share of the AC voltage changes. The higher frequency reduces the reactance of the capacitor to one-tenth its earlier value - i.e. 159.2Ω . The capacitor takes a much lower share of the AC voltage;
 - the output impedance of the signal generator may change.
- Repeat the calculations at 1kHz, and check your results against the measured values.

For your records:

- At a frequency f , the reactance of a capacitor is: $X_C = 1 / (2 \pi f C)$.
- The impedance of a C-R circuit is: $Z = (R^2 + X_C^2)^{1/2}$.
- The rms current is given by: $I = V_S / Z$ where $V_S = \text{AC supply rms voltage}$.
- The resulting rms voltage across the resistor is $V_R = I \times R$.
- The resulting rms voltage across the capacitor $V_C = I \times X_C$.

Worksheet 19

L-C-R series circuit

Intermediate electrical and electronic principles

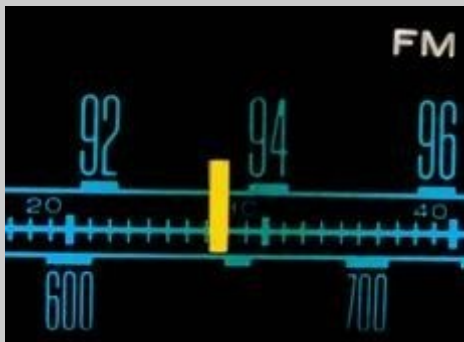

At this point, AC circuits become very interesting!

In inductors, reactance increases with frequency. In capacitors it decreases with frequency, and in resistors frequency has no effect

A series LCR circuit has all three, though the resistance may be that of the inductor wire itself, rather than that of a discrete resistor.

At one particular frequency, the *resonant frequency*, the circuit

Over to you:

- Connect a 47mH inductor and a 1 μ F capacitor in series, as shown in the circuit diagram.
- Set the signal generator to output an AC voltage at a frequency of 100Hz.
- Remove the connecting link at **A**, and connect a multimeter, set to read up to 20mA AC, in its place.
- Record the current flowing at point **A** in the table.
- Remove the multimeter and replace the link.
- Set up the multimeter to read AC voltages of up to 20V. Connect it to measure the signal generator output voltage, V_s , and record it in the table.
- Change the frequency to 200Hz, and repeat the measurements. Again record them in the table.
- Repeat the measurements for each of the frequencies listed and record them in the table.

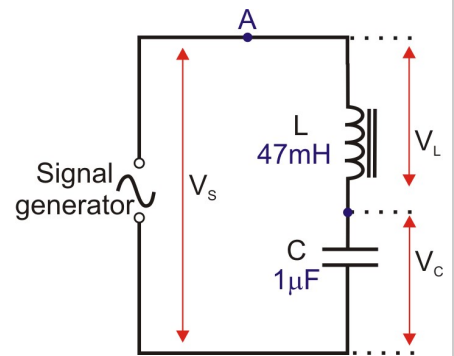

Frequency in Hz	Sig. gen. output V_s	Current at A in mA	Impedance in $k\Omega$
100			
200			
300			
400			
500			
600			
700			
800			
900			
1000			

Worksheet 19

L-C-R series circuit

Intermediate electrical and electronic principles

So what?

- Your results table may not make it obvious what is happening, partly because the output impedance of the AC power supply will probably have an effect on output voltage. This will become clearer when we look at the impedance of the circuit.
- Complete the table, by calculating the impedance, Z , at each frequency, using the formula:

$$Z = V_S / I$$
- At low frequencies, the capacitor has a high reactance, and the inductor a low reactance.
- As the frequency rises, the capacitor's reactance falls, but the inductor's reactance increases.
- At one value of frequency, called the resonant frequency, the combined effect of the two is a minimum.
At this frequency, the impedance of the circuit is a *minimum*.
- Plot a graph of impedance against frequency, and use it to estimate the resonant frequency. A typical frequency response curve is shown below.

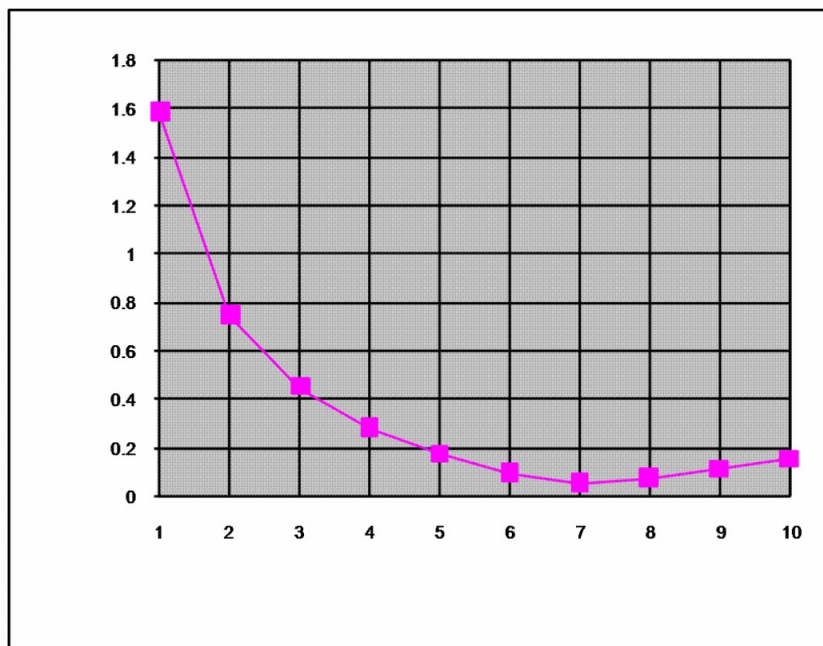

For your records:

For a series LCR circuit, the impedance is a minimum at the resonant frequency, f_R .

This can be calculated from the formula $f_R = 1 / 2 \pi \sqrt{L \times C}$

Worksheet 20

Transformers

Intermediate electrical and electronic principles



A huge advantage of generating electricity as AC is that it allows the use of transformers, to step-up or step-down an AC voltage to any desired value.

Our treatment of the transformer links it, in four steps, to the principles we met earlier, where we saw that an electric current is generated when a magnetic field moves across a conductor.

In the transformer, the moving magnetic field is produced by an electromagnet supplied with AC.



Over to you:

Step 1 - Moving the magnet:

- Build the arrangement shown opposite.
- Suitable oscilloscope settings are given below.
- Plunge a magnet into the coil, and then pull it out, watching the oscilloscope as you do so.

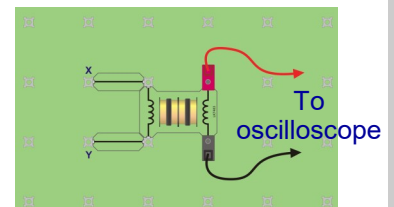

Step 2 - Electromagnet, not magnet:

- Now, connect the second coil, at **X** and **Y**, to a DC power supply, set to 3V.
- Switch the DC supply on and off, watching the trace as you do so.

Step 3 - AC not DC:

- This time, create a moving magnetic field by connecting points **X** and **Y** to a signal generator, set to an amplitude of 3V and a frequency of around 1kHz.
- Switch on the signal generator, and watch the trace.

Step 4 - Intensify the field:

- Slide a ferrite core down the middle of the two coils, and notice the effect this has.
- We now have a simple but very inefficient transformer!

Optional extension:

Investigate the effect of:

- changing the amplitude of the AC supply from the signal generator;
- changing the frequency of the AC supply from the signal generator;
- linking the coils with cores made from other materials, like steel, instead of ferrite.

Typical oscilloscope settings:

Timebase	Steps 1 and 2: 1s/div	Steps 3 and 4: 1ms /div	(X multiplier x1)
Voltage range	Input A - $\pm 500\text{mV DC}$ (Y multiplier x1)	(needs increasing for step 4.)	
	Input B - Off		

Worksheet 20

Transformers

Intermediate electrical and electronic principles

So what?

The pictures show typical traces for this investigation:

- the upper one shows current spikes generated when the DC supply to the second coil is switched on and off.
- the lower one shows current generated when the second coil is connected to the AC supply .

We saw earlier that the essential ingredients to generate electricity are a magnet, wire and movement. Here, we have replaced the magnet with an electromagnet (second coil), and produced movement by using an alternating magnetic field.

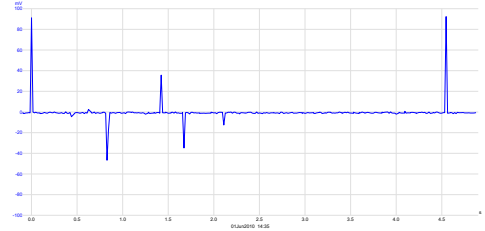

w20e

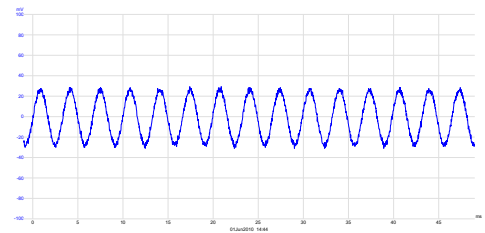

w20d

One coil, called the **primary**, is supplied with AC current, and generates an alternating magnetic field. This links with the other coil, called the **secondary**. As a result, an alternating voltage is generated in the secondary. This is the principle of the transformer.

Some refinements:

- The *strength* of the magnetic field in the primary depends on factors like:
 - the number of turns of wire in the primary coil
 - the current flowing through it, which, in turn, depends on the voltage applied to it.
- The *voltage* generated in the secondary coil depends on factors like:
 - the strength of the magnetic field generated by the primary
 - the number of turns of wire in the secondary coil
 - how effectively the magnetic field of the primary links with it.

In other words, the voltage generated in the secondary depends on the number of turns in the primary, and the number of turns in the secondary. The next worksheet explores this link.

For your records:

- Copy the circuit symbol for the transformer, given at the top of the previous page.
- Describe the role played by each of the three components in the transformer:
 - the primary coil,
 - the secondary coil,
 - the core.

Worksheet 21

Practical transformers

Intermediate electrical and electronic principles

Transformers play an important role in many electrical and electronic applications by allowing AC voltages to be stepped up or down to any desired value.

In this worksheet you investigate the operation of a small transformer, which has a laminated steel core, when used for step-down and then step-up operation.



Over to you:

Step-down transformer:

In a step-down transformer, the primary coil, the one supplied with AC power, has more turns of wire than the secondary, the one that generates the transformer output voltage.

Here we use a commercial transformer with a turns ratio of 2:1, meaning that one coil has twice as many turns as the other. The primary will be the '2' coil, and the secondary the '1' coil.

- Build the system shown, which delivers power to a 1kΩ load. (Ignore any labelling on the transformer itself.)
- Connect a signal generator to the '2' coil (primary), using the low impedance output (typically 50Ω.) Set it to output a sine wave with frequency 300Hz, and amplitude 6.0V. (If in doubt, check these with your instructor.)
- Connect a multimeter, set on the 20V AC voltage range, to measure voltage V_P across the primary (the '2') coil, and then V_S across the secondary (the '1' coil.)
- Set the multimeter to the 20mA AC current range, and connect it to replace the link below the '2' coil, to read the primary current, I_P .
- Replace the connecting link and measure the secondary current, I_S in the same way.
- Record all measurements in the table.

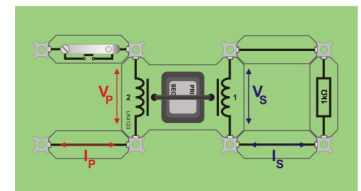

Step-up transformer:

In a step-up transformer, the primary coil has fewer turns than the secondary. In this case, the primary will be the '1' coil, and the secondary the '2' coil.

- The system is the same as above, except that the transformer carrier is now upside down.
- Connect the multimeter to measure the secondary voltage V_S . Adjust the amplitude of the signal from the signal generator until V_S is the same as in the previous investigation.
- Now measure and record V_P , I_P and I_S .

Reading	Step-down	Step-up
V_P		
V_S		
I_P		
I_S		

Worksheet 21

Practical transformers

Intermediate electrical and electronic principles

So what?

The last worksheet looked at transformer principles, but the final device was very inefficient. This one uses an improved version - two coils, side by side, as before, but linked by a much more elaborate core, threading through the centre of the coils, and wrapped around the outside too. The result - more effective linkage between the magnetic field generated in the primary and the secondary coil.

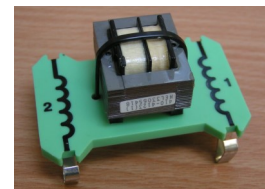

What the results show:

- Look at the ratio $V_P:V_S$ for both step-up and step-down transformers. The transformer equation says that, for an ideal transformer:

$$V_P / V_S = N_P / N_S$$

where N_P and N_S are the number of turns on the two coils.

- Next look at the ratio $I_P:I_S$ for both transformers.

In general terms:

- a step-up transformer 'steps up' the voltage (virtually doubles it) but 'steps down' the current - I_P is much greater than I_S .
- a step-down transformer 'steps down' the voltage, but delivers the same secondary current for a much smaller primary current.
- Both delivered the same voltage, V_S , to the $1k\Omega$ load, and so I_S , the secondary current, was very similar in both cases.

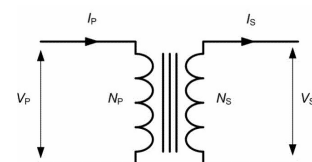
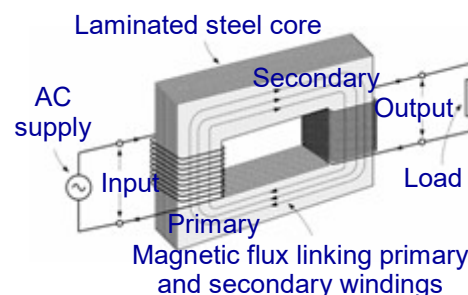

The acid test:

What about the power? Was it stepped up or stepped down?

Using the formula:

Power = Current x Voltage:

Power delivered to the primary coil, $P_P = I_P \times V_P = \dots\dots\dots$ mW

Power delivered from the secondary, $P_S = I_S \times V_S = \dots\dots\dots$ mW

For an ideal transformer (100% efficient): $P_P = P_S$

and $I_S / I_P = N_P / N_S$

(Optional extension:)

- Investigate the effect of applied frequency on the output of the transformer. Research the topic of power matching to explain your results.

For your records:

- Copy the transformer equation, and explain what it means, in words.
- Explain what is meant by 'step-up' and 'step-down' when applied to transformers. Include the role of the number of turns of wire, and specify exactly what is stepped up, and what is stepped down in each case.

Worksheet 22

Diode characteristics

Intermediate electrical and electronic principles

Diodes allow current to flow in one direction but not the other. The performance of a diode can be illustrated by plotting a graph of 'forward' and 'reverse' current against the applied voltage. This graph allows us to predict accurately how a diode will behave in a particular circuit and decide whether or not it is suitable that application.

In this worksheet you compare the characteristics of two different diodes. One is a general purpose low-voltage silicon diode (1N4001) whilst the other is made from germanium (OA91).

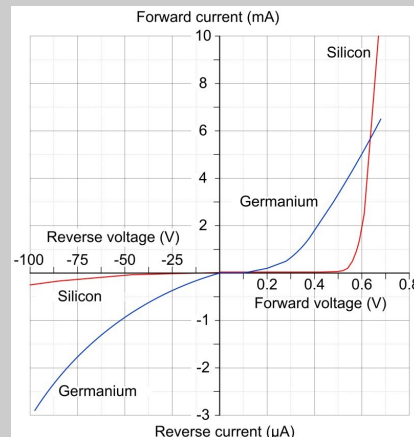

Over to you:

- Build the circuit shown opposite, to allow you to measure the **forward** characteristics of the diodes.
- Set the DC power supply for an output of 4.5V.
- Set the voltmeter to the 20V DC range and the ammeter to the 20mA DC range.
- Use the 'pot' to vary the voltage, V_F , applied to the diode from 0.1V to 0.7V in steps of 0.1V.
- At each step, measure and record the forward current, I_F , in the table.
- Repeat this procedure for the other diode.
- Next invert the diode, and change the power supply voltage to 12V, as shown in the lower diagram, .This allows you to measure the **reverse** characteristics of the two diodes.
- Change the ammeter to the 200 μ A DC range.
- Once again, use the 'pot' to vary the voltage applied to the diode, now called V_R , but this time you will only need to take current readings, I_R , at 0V, 5V and 10V.
- Record them in the table.
- Repeat the process for the other diode.

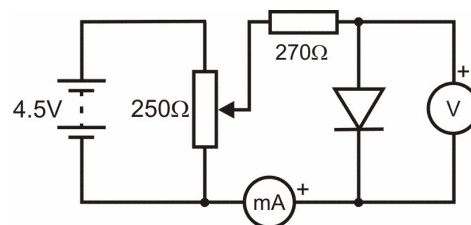

Forward characteristics		
V_F	I_F (1N4001)	I_F (OA91)
0		
0.1		
0.2		
0.3		
0.4		
0.5		
0.6		
0.7		

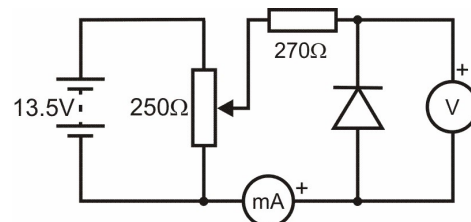

Reverse characteristics		
V_R	I_R (1N4001)	I_R (OA91)
0		
5.0		
10.0		

Worksheet 22

Diode characteristics

Intermediate electrical and electronic principles

So what?

- Use the axes like those shown below to plot your results as graphs of applied voltage against current for both the forward and reverse directions and for both diodes. Notice that the voltage and current scales are different for the two directions.

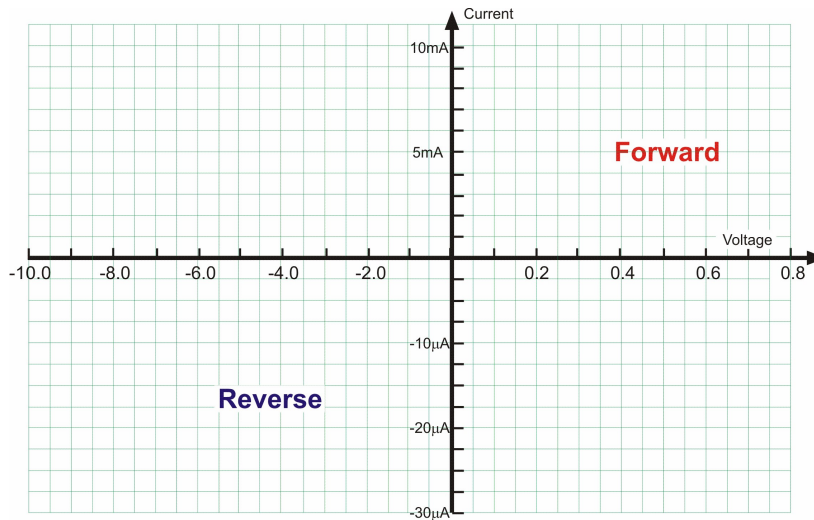

- Describe what you about the behaviour of the two kinds of diode.
- What forward voltage is required to make each of the diodes begin to conduct?

Silicon

Germanium

the graphs tell

For your records:

- Diodes are usually made from semiconducting crystals. The behaviour of the device depends on the material it is made from, as the graph shows.
- The diode is a 'one-way valve'. It allows a current to flow through it in only one direction. (A resistor behaves in exactly the same way no matter which way the current flows. Try it !)
- When it is forward-biased, a silicon diode conducts, with a voltage drop of about 0.7V across it.
- When reverse-biased, it does not conduct (for low voltages, at any rate.)
- When forward-biased, a germanium diode conducts, with a voltage drop of about 0.3V across it.

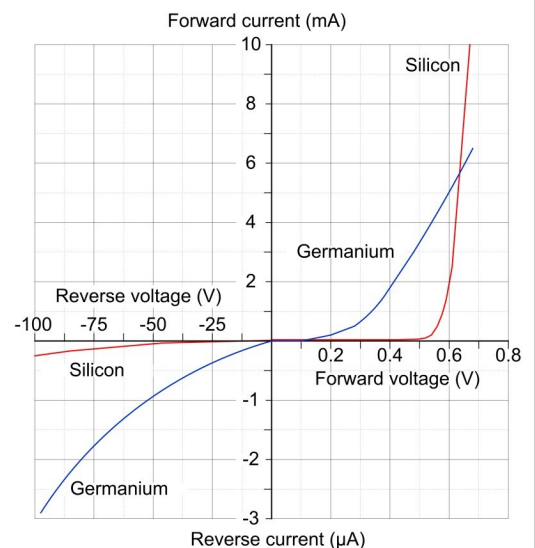

Worksheet 23

Half-wave rectifier

Intermediate electrical and electronic principles

One of the most common applications for a diode is to convert alternating current (AC) to direct current (DC) in a **rectifier** circuit. This exploits the unidirectional properties of a diode - current flows only when the anode is positive with respect to the cathode.

The next issue is to maintain the current flow while the diode is not conducting. This involves the use of a large value capacitor acting as a **reservoir** for charge. This maintains current flow, and output voltage, until the diode conducts again.



Over to you:

- Build circuit **A**. The AC power supply provides the input. The 180Ω resistor acts as the load for the rectifier circuit.
- Connect a DC voltmeter to measure the DC output voltage, V_{OUT} . Record it in the first line of the table.
- Connect a dual trace oscilloscope, using two 'x10' probes, so that channel A displays at least two complete cycles of the input waveform and channel B displays the corresponding output. Connect the oscilloscope ground terminals to the negative rail of the circuit.
- Modify the circuit by adding a $47\mu\text{F}$ capacitor, C, connected as in circuit **B**.
Take care to connect it the right way round, as shown!
- Notice the effect on the oscilloscope trace.
- Again measure and record the output voltage, V_{OUT} .
- Repeat this process for all the other values of capacitor C, given in the table.

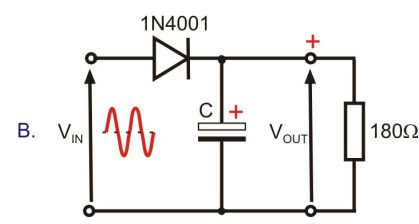
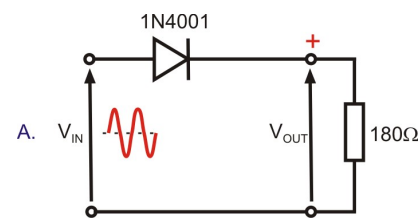

Capacitor	V_{OUT}
None - circuit A	
$47\mu\text{F}$	
$100\mu\text{F}$	
$150\mu\text{F}$	
$1000\mu\text{F}$	

Typical oscilloscope settings:

Timebase 10 ms/div

Voltage range (Both Inputs) $\pm 5\text{V DC}$ with x10 probes

Trigger Mode Repeat

ch.A

Trigger Channel

Trigger Direction Rising

Trigger Threshold - 4 mV

Worksheet 23

Half-wave rectifier

Intermediate electrical and electronic principles

So what?

The diode allows current to flow through it (and the load) in one direction only. It acts as a small resistor for currents trying to flow in one direction (when it is forward-biased,) and as a very large resistor for currents trying to flow in the other direction, (when reverse-biased.)

The first diagram shows a typical trace obtained from the first circuit. The AC input is turned into a DC output (rectified.) Notice that, while the output is DC (as it never crosses the 0V line,) it is not steady DC.

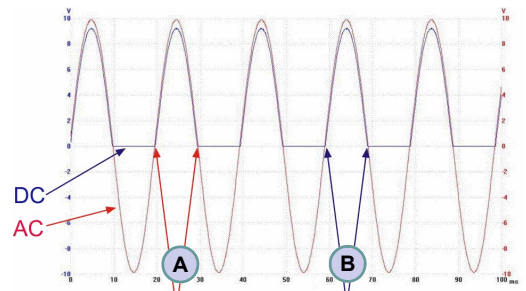

A - AC current changes direction here
B - DC current does not change direction

The second diagram shows the same signal, using a different time base setting for the oscilloscope (2ms/div.) to show the rectification in more detail.

In particular, notice that the DC output, (the lower one), is approximately 0.7V lower than the AC input. The diode does not really conduct until the voltage across it reaches 0.7V. Thereafter, there is a 0.7V drop across the diode, leaving the DC output 0.7V below the AC input at all points.

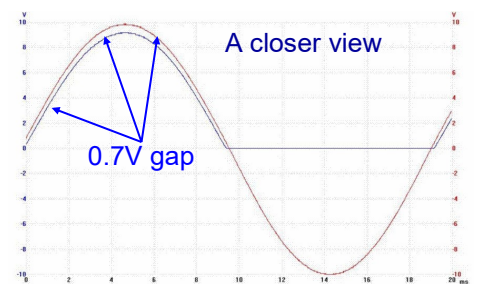

The third diagram shows the effect of adding a smoothing capacitor. The output voltage is now both DC and steady.

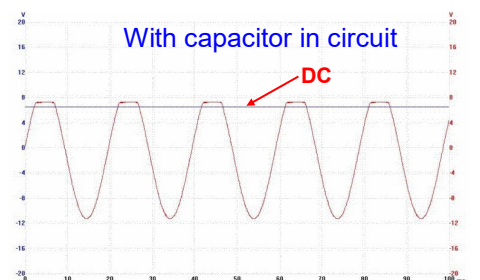

For your records:

- Sketch a voltage-time graph for the output signal for circuit **A**.
- Sketch a voltage-time graph for the output signal for circuit **B** with the 1000 μ F capacitor.
- Explain the difference between these two graphs.
- Which value of reservoir capacitance produced the highest value of DC output voltage? Why was this?

Worksheet 24

Full-wave bridge rectifier

Intermediate electrical and electronic principles

The diode in a half-wave rectifier conducts for no more than 50% of the time. This is inefficient and requires large reservoir capacitors.

Most practical power supplies use four diodes to maintain the current flow through the load on both positive and negative half-cycles of the supply.

In practice, they use either four individual diodes (as shown opposite) or a single component, a bridge rectifier, where the four diodes are encapsulated in a single package.

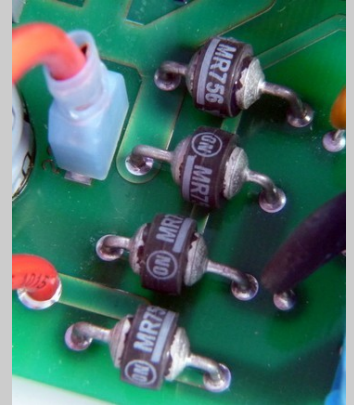

Over to you:

- Build the circuit shown opposite, using the AC power supply as the input once again.
- Measure the DC output voltage, V_{OUT} and record it in the first line of the table (for 'Capacitor - None').
- Using the same time base and voltage sensitivity settings as before, connect an oscilloscope to display at least two complete cycles of the **output**.

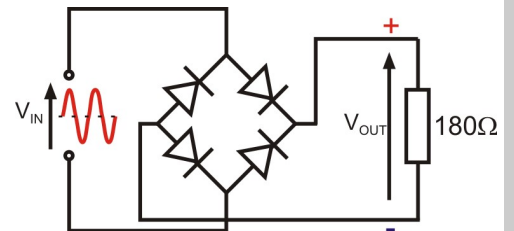

Do not try to display the input waveform at the same time.

The common ground connection will short-circuit one of the diodes!

The input waveform is the same as that displayed in the previous worksheet.

- Modify the circuit by adding a $47\mu\text{F}$ reservoir capacitor, C , as in the second circuit.

Take care to connect it the right way round, as shown!

- Notice the effect on the oscilloscope trace.
- Measure and record the DC output voltage, V_{OUT} .
- Use each of the other capacitor values shown in the table. Measure and record the DC output voltage, V_{OUT} , for each.

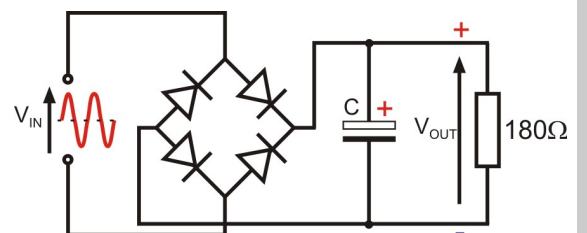

Capacitor	V_{OUT}
None	
$47\mu\text{F}$	
$100\mu\text{F}$	
$150\mu\text{F}$	
$1000\mu\text{F}$	

Worksheet 24

Full-wave bridge rectifier

Intermediate electrical and electronic principles

So what?

The circuit diagram for the full-wave rectifier is shown opposite.

It was pointed out that you cannot measure the input and output waveforms simultaneously.

To do that, you would connect one channel to points **A** and **C** to measure the input, and the other to points **B** and **D** to measure the output. However, most oscilloscopes have a common 0V connection between the two channels. This would connect points **C** and **D** together, say, and thus short-circuit one of the diodes.

The three oscilloscope traces show typical waveforms for:

- the AC signal going into the full-wave rectifier,
- the DC output
- the effect of the reservoir capacitor.

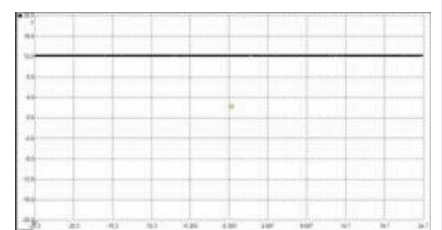
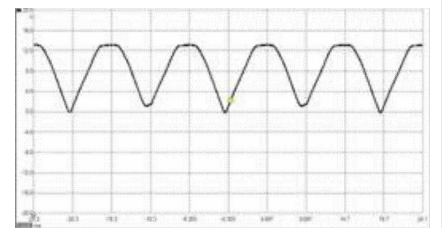
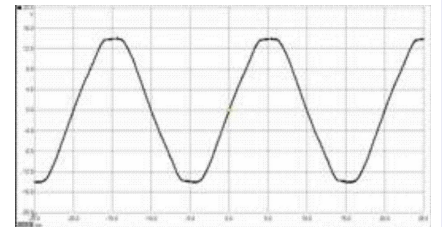
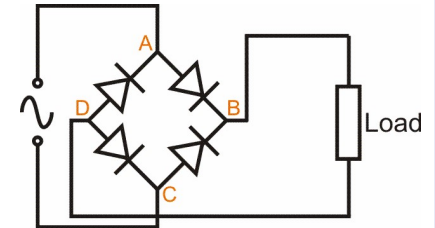

The DC output, in the middle trace, is an improvement on the half-wave output, in that current flows through the load throughout the AC cycle. Again, it is DC, because the trace never crosses the 0V line. However, again, a reservoir capacitor is needed to provide **smooth** DC.

For your records:

- Sketch a voltage-time graph of the full-wave rectified DC output signal, without smoothing.
- Compare the performance of the full-wave rectifier with the half-wave rectifier. Which circuit performed the best, and why?
- The output of this full-wave rectifier, using four diodes, is 1.4V less than the AC input peak value, and is not smooth DC.
- Again, a large capacitor can be connected across the output of the rectifier to smooth the DC signal produced.

Revision questions

Intermediate electrical and electronic principles

About these questions

These questions are designed to provide you with a useful aid to revision. You should allow 25 minutes to answer them and then check your answers with those given on page 54.

1. When six 1.5V dry cells are connected in series the resulting battery voltage will be:

- (a) 1.5V
- (b) 6V
- (c) 9V

2. A sine wave has a frequency of 40ms. What is its frequency?

- (a) 25Hz
- (b) 40Hz
- (c) 80Hz

3. The components shown on the right are:

- (a) resistors.
- (b) capacitors.
- (c) inductors.

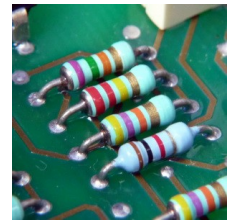

4. A sine wave has a peak value of 10V. What is its rms value?

- (a) 5V
- (b) 7.07V
- (c) 14.14V

5. The connection marked 'X' on the diode shown in the right is the:

- (a) anode.
- (b) base.
- (c) cathode.

6. Ohm's Law states that:

- (a) $V = I R$
- (b) $V = I / R$
- (c) $V = R / I$

7. Inductive reactance:

- (a) increases with frequency.
- (b) decreases with frequency.
- (c) does not change with frequency.

8. If the frequency of the current flowing in a resistor is doubled the current will:

- (a) be doubled.
- (b) be halved.
- (c) stay the same.

9. The component shown on the right is:

- (a) a resistor.



Revision questions

Intermediate electrical and electronic principles

- (b) an inductor.
- (c) a capacitor.

10. The units of electric charge are:

- (a) amperes.
- (b) coulombs.
- (c) farads.



11. A potential difference of 120V appears across a resistance of 15kΩ.

Which one of the following gives the current that will be flowing in the resistor?

- (a) 8mA
- (b) 125mA
- (c) 180mA

12. A transformer has an input of 120V and a turns ratio of 4:1. What will the output voltage be:

- (a) 30V
- (b) 60V
- (c) 480V.

13. In a series L-C-R circuit at resonance, the impedance will be:

- (a) maximum.
- (b) minimum.
- (c) zero.

14. Which one of the following gives the peak value and frequency of the waveform shown opposite:

- (a) 5V, 500Hz
- (b) 5V, 2Hz
- (c) 10V, 2000Hz

15. Which one of the following gives the units of electrical energy?

- (a) amperes
- (b) joules
- (c) watts

16. A diode will conduct when:

- (a) the anode is made positive with respect to the cathode.
- (b) the cathode is made positive with respect to the anode.
- (c) the anode and cathode are at exactly the same potential.

17. When a diode is forward biased it will:

- (a) exhibit a very low resistance.
- (b) exhibit a very high resistance.
- (c) exhibit no resistance at all.

18. Which one of the following gives the forward voltage normally associated with a silicon diode?

- (a) 0.1V
- (b) 0.6V
- (c) 2.0V

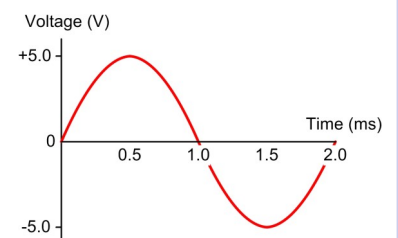

Revision questions

Intermediate electrical and electronic principles

19. In the reverse direction a diode will conduct:
- (a) a large amount of current.
 - (b) the same current as in the forward direction.
 - (c) hardly any current at all.
20. The function of a reservoir capacitor in a power supply is to:
- (a) transform the input voltage to the required level.
 - (b) release charge when the rectifier diode(s) are non-conducting.
 - (c) convert half-wave operation to full-wave operation.
21. Resistors of 15Ω and 60Ω are connected in series across a 15V supply. Which one of the following gives the voltage dropped across the 60Ω resistor?
- (a) 3V
 - (b) 12V
 - (c) 15V
22. An capacitor with a reactance of 150Ω is connected in series with a 200Ω resistor. Which one of the following gives the impedance of the circuit?
- (a) 50Ω
 - (b) 250Ω
 - (c) 350Ω
23. At 400Hz the reactance of a capacitor is 300Ω . At 1.6kHz its reactance will be:
- (a) 75Ω
 - (b) 150Ω
 - (c) 1200Ω
24. The component shown on the right is a:
- (a) resistor.
 - (b) capacitor.
 - (c) transformer.
25. The output of rectifier will be kept more constant by using:
- (a) a relatively small value of reservoir capacitance.
 - (b) a relatively large value of reservoir capacitance.
 - (c) no reservoir capacitance at all.

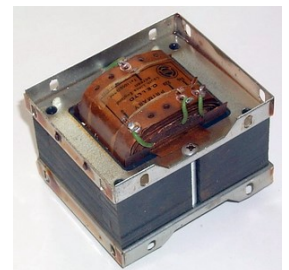

q24

Answers to revision questions

Intermediate electrical and electronic principles

Answers to revision questions (see page 51)

1. (c)
2. (a)
3. (a)
4. (b)
5. (c)
6. (a)
7. (a)
8. (c)
9. (b)
10. (b)
11. (a)
12. (a)
13. (b)
14. (a)
15. (b)
16. (a)
17. (a)
18. (b)
19. (c)
20. (b)
21. (b)
22. (b)
23. (a)
24. (c)
25. (b)

Tutor's notes

Intermediate electrical and electronic principles

About this course

Introduction

This workbook is intended to reinforce the learning that takes place in the classroom or lecture room for intermediate level courses such as the BTEC National unit (QCF Level 3) in Electrical and Electronic Principles (J/600/0255). It provides a series of practical activities and investigations, designed to complement the BTEC syllabus.

The learning outcomes are as follows:

- Use circuit theory to determine voltage, current and resistance in direct current (DC) circuits.
- Understand the concepts of capacitance and determine capacitance values in DC circuits.
- Know the principles and properties of magnetism.
- Be able to use single-phase alternating current (AC) theory.

Locktronics equipment makes it simple and quick to construct and investigate simple electrical and electronic circuits. Thanks to the symbols printed on each component carrier, the result can look exactly like the circuit diagram.

Prior Knowledge

Students should have previously studied (or should be concurrently studying) Module 1 (Mathematics) and Module 2 (Physics) or should have equivalent knowledge at Level 2.

Learning Objectives

On successful completion of this course the student will have learned:

- to use a multimeter and oscilloscope to carry out basic DC and AC circuit measurements;
- to identify series and parallel branches within a circuit network;
- the relationship between current, voltage and resistance in simple DC and AC circuits;
- the relationships between power, voltage, current, resistance, energy and time
- the relationship between resistance, reactance and impedance in an AC circuit;
- the relationship between charge, voltage and capacitance;
- the relationship between motion, current flow and induced emf;
- the relationship between reactance, frequency and capacitance (or inductance);
- the behaviour of a series resonant L-C-R circuits;
- the relationship between Q-factor and bandwidth;
- the relationship between turns ratio, voltage ratio and current ratio for an ideal transformer
- the behaviour of a diode when forward and reverse biased;
- the operation of simple half-wave and full-wave (bridge) rectifiers.

Tutor's notes

Intermediate electrical and electronic principles

What students will need:

Students need the equipment shown in the table, together with the following items of test equipment:

- 1 digital multimeter
- 1 oscilloscope (single or dual trace)
- 1 audio frequency signal generator with low-impedance output (preferably 50Ω , or less).

In addition, students may need a small supply of thin card and two aluminium plates in order to complete Worksheet 10 (optional). A multimeter with a capacitance range will also be required for this investigation.

Power source:

The majority of the investigations in this workbook require a DC power source such as the HP2666, which is an adjustable DC power supply offering output voltages of 3V, 4.5V, 6V, 7.5V, 9V or 12, with currents typically up to 1A.

The voltage is changed by turning the selector dial just above the earth pin until the arrow points to the required voltage. Tutors may decide to make any adjustment necessary to the power supply voltage themselves, or may allow students to make necessary changes.

The two power supply worksheets require the use of an 12V 1A AC supply such as the HP3728. This is a fixed voltage supply. Alternative versions are available for use in Europe and the USA.



Locktronics HP2666 power supply showing voltage selector.

Qty	Code	Description
1	HP2045	Plastic tray
1	HP2666	Power supply
1	HP4039	Tray Lid
1	HP5540	Deep tray
1	HP7750	Daughter tray foam cutout
1	HP7750	Daughter tray foam cutout
1	HP9564	62mm daughter tray
1	HP9564	62mm daughter tray
1	LK0123	Small bar magnet
1	LK2340	AC voltage source carrier
3	LK2346	MES bulb, 12V, 0.1A
1	LK3982	Voltmeter, 0V to 15V
1	LK4000	Locktronics User Guide
1	LK4002	Resistor, 100 ohm, 1W, 5% (DIN)
1	LK4003	Capacitor, 1,000 uF, Electrolytic 30V
1	LK4123	Transformer, 2:1 turns ratio
1	LK5202	Resistor, 1k, 1/4W, 5% (DIN)
2	LK5203	Resistor, 10k, 1/4W, 5% (DIN)
1	LK5205	Resistor, 270 ohm, 1/2W, 5% (DIN)
1	LK5207	Resistor, 180 ohm, 1/2W, 5% (DIN)
1	LK5208	Potentiometer, 250 ohm (DIN)
1	LK5224	Capacitor, 47uF, Electrolytic, 25V
1	LK5242	Diode, germanium
1	LK5243	Diode, power, 1A, 50V
12	LK5250	Connecting Link
1	LK5266	Bridge rectifier
3	LK5291	Lampholder, MES
2	LK5570	Pair of leads, red and black, 600mm, 4mm to croc clip
2	LK5607	Lead, yellow, 500mm, 4mm to 4mm stackable
2	LK5609	Lead, blue, 500mm, 4mm to 4mm stackable
1	LK6202	Capacitor, 100uF, Electrolytic, 25V
1	LK6203	Capacitor, 2,200 uF, Electrolytic, 25V
1	LK6205	Capacitor, 1 uF, Polyester
1	LK6207	Switch, push to make, metal strip
1	LK6211	Resistor, 22k, 1/4W, 5% (DIN)
1	LK6214R2	Choke, 47mH
1	LK6218	Resistor, 2.2k, 1/4W, 5% (DIN)
1	LK6223	Capacitor, 150 uF, Electrolytic, 25V
1	LK6492	Curriculum CD ROM
3	LK7409	AA battery holder carrier
1	LK7483	1:1 transformer with retractable ferrite core
1	LK8275	Power supply carrier with battery symbol
1	LK8900	7 x 5 metric baseboard with 4mm pillars
1	LK9381	Ammeter, 0mA to 100mA
1	LK9998	400 Turn coil carrier

Tutor's notes

Intermediate electrical and electronic principles

Using this course:

It is expected that the worksheets are printed / photocopied, preferably in colour, for the students' use. Students should retain their own copy of the entire workbook.

Worksheets usually contain:

- an introduction to the topic under investigation;
- step-by-step instructions for the practical investigation that follows;
- a section headed 'So What?' which aims both to challenge learners by questioning their understanding of a topic and also provides a useful summary of what has been learned. It can be used to develop ideas and as a trigger for class discussion.
- a section headed 'For Your Records' which provides important summary information that students should retain for future reference.

This format encourages self-study, with students working at a rate that suits their ability. It is for the tutor to monitor that students' understanding is keeping pace with their progress through the worksheets and to provide additional work that will challenge brighter learners. One way to do this is to 'sign off' each worksheet, as a student completes it, and in the process have a brief chat with the learner to assess their grasp of the ideas involved in the exercises that it contains.

Finally, a set of multiple choice revision questions has been provided to conclude the work in this unit. These questions are of mixed difficulty and are designed to help students identify topics which might need more work. It is recommended that students should attempt these questions under examination conditions and without the use of notes.

Time:

It will take most students between eleven and eighteen hours to complete the full set of worksheets. It is expected that a similar length of time will be needed to support the learning in a class, tutorial or in a self-study environment.

Tutor's notes

Intermediate electrical and electronic principles

Worksheet	Notes for the Tutor	Timing
1	<p>In the first worksheet, students investigate the series and parallel connection of cells in order to produce batteries. Before this, students should be introduced to the different types of cell and to the distinction between primary and secondary types. It is also important for students to know the basic characteristics of several of the most common types of cell, including lead-acid, alkaline, nickel-cadmium and zinc-carbon types.</p> <p>Series and parallel connection of batteries should be described together with representative circuit diagrams. Students need to be aware that the same load current flows through all cells in a series-connected battery but is shared between the cells in the case of a parallel-connected battery.</p> <p>Students are asked to construct three arrangements of series-connected cells and three arrangements of parallel-connected cells. By comparing the measured voltages, they confirm what they have previously learned about series and parallel combination of individual cells.</p>	20 - 30 minutes
2	<p>This worksheet introduces students to the use of a multimeter to measure the current flowing in a circuit. Where multimeters are not available, tutors may wish to use discrete meters but these must be of comparable sensitivity.</p> <p>Multimeters are in widespread use because of their low cost and versatility. Although they differ in terms of the functions they offer and the precise details of their structure, the broad principles are the same. Here we look at their use to measure current (ammeter function) and later voltage (voltmeter function.)</p> <p>We address the distinction between DC ranges and AC ranges, without going into detail about DC and AC.</p> <p>Beware! It is common to find that the ammeter settings are protected by an internal fuse. This is frequently 'blown' because students switch on the multimeter, connected as a voltmeter, with the dial turned to a current range. Teachers should check all fuses prior to this exercise, and be prepared with a supply of replacement fuses!</p> <p>The aim of the exercises is to spot the pattern for current flow - that the total current leaving any junction in the circuit is equal to the total current entering the junction. (Compare this with traffic at a road junction, where crashes and parking can lead to a different result.)</p> <p>The worksheet ends with an additional exercise and questions, requiring students to apply the current rule that they discovered in the investigation.</p>	20 - 30 minutes

Tutor's notes

Intermediate electrical and electronic principles

Worksheet	Notes for the Tutor	Timing
3	<p>This worksheet mirrors the structure of the last one, but looks at measuring voltage rather than current.</p> <p>The point is made in the introduction, that it is relatively easy to visualise an electric current - millions of electrons slowly squeezing their way along a wire, like crowds of people in a shopping mall, but that it is more difficult to visualise voltage. It is a topic we return to in a later workbook.</p> <p>For the present, the exercise concentrates on measuring voltage, rather than defining it. Students use a multimeter for this, by connecting it in parallel with the section of the circuit under investigation.</p> <p>The circuit diagram at the top of the second page of the worksheet shows three voltmeters. The student does not need three, but can move one from one voltmeter position to the next to take the three readings.</p> <p>Again, students are asked to look for a pattern in their results. This is that the total of the voltmeter readings in any loop of the circuit is equal to the power supply, or battery, voltage.</p> <p>The worksheet ends with an exercise and questions, requiring students to apply the voltage rule.</p>	20 - 30 minutes
4	<p>This worksheet focuses on Ohm's Law. It also introduces the use of a potentiometer as a simple variable voltage source. Students might need help in setting up the circuit. A picture is provided to assist with this.</p> <p>The instructions refer to use of an ammeter and a voltmeter. While it is possible to use a single multimeter to do both jobs, it is easier if each student has access to two multimeters. If using only one, once the current is measured, a connecting link must replace the ammeter, while the multimeter is acting as a voltmeter.</p> <p>The voltage adjustment is delicate, and students should be encouraged to have patience when setting it to the values given in the table.</p> <p>In reality, Ohm's Law applies only when a very specific set of circumstances apply. In particular, the temperature of the conductor, (a resistor in this case,) must not change. As the current through it increases, the resistor gets hot! We attempt to limit this by specifying a maximum of 1.0V across the resistor. The students plot a graph of their results, and can use it to obtain a value for the resistance of the resistor.</p> <p>The next section introduces the resistor colour code. Tutors should spend time giving further examples of its use.</p> <p>A guide on using a multimeter to measure resistance follows,. The most important aspect of this is that this cannot be done 'in-circuit'. The component must be removed from the circuit for the measurement.</p> <p>The worksheet ends with questions on using Ohm's Law formulae, and on applying the resistor colour code (see Intermediate Electronics, LK9284, for a colour chart for the four-band resistor colour code).</p>	20 - 30 minutes

Tutor's notes

Intermediate electrical
and electronic principles

Worksheet	Notes for the Tutor	Timing
5	<p>This investigation introduces students to series and parallel circuits. As before, this involves similar multimeter skills, and pitfalls. Instructors should again be aware of the internal fuse issue.</p> <p>The treatment compares measured values with calculated ones. Instructors might decide at this point to discuss component and instrument tolerance. Inspection of the resistors beneath the carriers will show them to have either 5% or 1% tolerance. Measuring instruments have a range of accuracies, depending on what scale they are on. Where available, students could be directed to manufacturer's data.</p> <p>The worksheet ends with a network for students to analyse. The outcome of their calculations will indicate how well they have assimilated the contents of the earlier worksheets.</p>	20 - 30 minutes
6	<p>Voltage dividers are a very important in electricity and electronics as they form the basis for many sensing subsystems, such as light-sensing units.</p> <p>They can also appear difficult to students. The aim here is to overcome that aura of difficulty by reducing the treatment to two simple stages:</p> <ul style="list-style-type: none"> • the sum of the voltages across the components equals the supply voltage; • the bigger the resistance of a component, the bigger its share of the supply voltage, - if one resistor has four times the resistance of the other, it gets four times as much voltage. <p>This approach is tested with three different pairs of resistors, and using two supply voltages.</p> <p>The output voltage depends only the supply voltage and the <i>relative</i> size of the resistors, (not their absolute resistance,) so that a voltage divider made from a 2Ω and a 1Ω resistor behaves much like one made from a 2MΩ and a 1MΩ resistor.</p> <p>However, the absolute values of resistance are important in two ways:</p> <ul style="list-style-type: none"> • Using very low values of resistance increases the current flowing through the voltage divider, and increases the power dissipation in the resistors. This is usually undesirable. • When another subsystem, which draws an appreciable current, is connected to the voltage divider output, this extra loading can change the output voltage of the voltage divider. This extra current flows through the upper resistor but not the lower resistor in the voltage divider. A useful rule of thumb says that the current flowing through the unconnected voltage divider should be at least ten times bigger than the current that will be drawn from it when the next subsystem is connected to its output. <p>It may be worth discussing these points with the students once they have completed this exercise.</p>	20 - 30 minutes

Tutor's notes

Intermediate electrical
and electronic principles

Worksheet	Notes for the Tutor	Timing
7	<p>This worksheet investigates current divider circuits, and compares and contrasts their behaviour with that just studied for voltage dividers.</p> <p>Current dividers do not have as many obvious applications as voltage dividers, though they are used in current measurement. It is often useful to measure only a fixed portion of the total current, and from that deduce the total current flowing. For example, if a current divider sends 10% of the total current through an ammeter, which then registers a current of 2.5A, then the total current flowing was 25A.</p> <p>In an approach parallel to that used for voltage dividers, the treatment looks at two simple ideas:</p> <ul style="list-style-type: none"> • the sum of the currents through the components equals the supply current; • the bigger the resistance of a component, the smaller its share of the current, so that if one resistor has four times the resistance of the other, it passes a current four times smaller. 	20 - 30 minutes
8	<p>This worksheet looks at two very important, but straightforward, rules of electricity, known as Kirchhoff's laws. In the light of modern knowledge about electricity, these are less impressive than they would have appeared in 1845 when they were first formulated. Nevertheless, they offer valuable tools for analysing networks of components.</p> <p>The current law states that the (vector) sum of the currents at any point in a circuit is zero, or in other words, the total current flowing out of any junction is equal to the total current flowing into the junction. It may need to be stressed to students that it is vital to take into account the direction in which a current is flowing, as well as its magnitude, when applying Kirchhoff's rule. We can now say that it is a consequence of the conservation of charge, or, in other words, that electrons are neither created nor destroyed as they flow around a circuit.</p> <p>The voltage law says that around any loop in a circuit (any possible path that an electron may flow around,) the sum of the emf's (energy given to the electrons,) is equal to the sum of the pd's (energy taken from the electrons). In other words, in a series circuit consisting of a 6V battery and two resistors, (so that there is only one possible loop,) the sum of the voltages across the resistors (which take energy from the electrons and heat up in the process, - the pd's) is equal to 6V (the energy which the battery gives to the electrons - the emf.) In reality, this rule is simply a restatement of the conservation of energy.</p> <p>The investigation looks at both these aspects, and takes measurements to justify them.</p>	20 - 30 minutes

Tutor's notes

Intermediate electrical and electronic principles

Worksheet	Notes for the Tutor	Timing
9	<p>Students should appreciate the relationship between energy, power (as the rate at which energy is used), voltage, current and time. The introduction uses three key facts (definitions) to arrive at the relationship $P = I \times V$.</p> <p>The investigation into three circuits is designed to give students experience of electrical calculations in the context of actual circuits.</p> <p>The questions will provide students with practice in applying the principles of power and energy in relationship to practical power distribution systems.</p>	20 - 30 minutes
10	<p>The first worksheet on capacitors is optional. The materials for this are NOT included in the Locktronics kit, as the essence of the investigation is that it uses everyday materials.</p> <p>The investigation, as described, uses aluminium plates, separated by cardboard, but equally, it could use aluminium kitchen foil and kitchen food wrapping such as 'ClingFilm'. (Commercially produced capacitors are mysterious packages that hide any details of inner structure.)</p> <p>Students investigate the construction and operation of a simple parallel plate capacitor, constructed from two square aluminium plates with area of around 80cm^2. The plates are separated by one or more squares of card, each having a thickness of around 0.2mm. The arrangement must be kept flat to ensure that the plates are truly parallel. They can be placed between two glass plates, then placed flat on a table, with a non-metallic weight, (such as a bag of sugar,) applied to the upper glass plate.</p> <p>The capacitance of this arrangement (with one single sheet of card) will be around 1nF and should be easily measurable using a digital multimeter with a 2nF or 20nF capacitance range.</p> <p>Care should be taken when assembling the apparatus to avoid short circuits and any unwanted stray capacitance.</p>	20 - 30 minutes
11	<p>Here students investigate the charging and discharging of a capacitor. They first investigate capacitor charging by connecting a 9V DC supply to a capacitor via a series resistor. A push-to-make switch is used to discharge it prior to making measurements. The capacitor will begin to charge as soon as the switch is released. Students need a clock or stopwatch with a sweep second hand or digital seconds display.</p> <p>The measurements are repeated for three different sets of C-R values. They then plot three different graphs from which to make inferences about the effect of time constant ($C \times R$) on the rate of charging.</p> <p>Students then investigate the discharge process. Now the push-to-make switch is first closed in order to charge the capacitor fully, and then released to start the discharge period,. Once again, measurements are repeated for three different sets of C-R values, from which three different graphs are drawn. The students make inferences about the role of time constant ($C \times R$) on the rate at which the capacitor is discharged.</p> <p>This worksheet provides the basis of a useful class discussion, on for example, just how long it takes to charge or discharge a capacitor. More able students will benefit from additional work based around a mathematical analysis of charge and discharge.</p>	30 - 45 minutes

Tutor's notes

Intermediate electrical and electronic principles

Worksheet	Notes for the Tutor	Timing
12	<p>This practical exercise needs careful attention. The effects being studied are small and easily missed. Students using digital multimeters, should be aware that these instruments sample the input signal periodically, so that short-duration pulses may be missed.</p> <p>Traditionally, students are nervous about using multimeters - selecting the right range, using the correct sockets, and so on. They may need a brief revision session beforehand. A potential complication is that many multimeters have an internal fuse to protect against overload on DC current ranges. These 'blow' very easily, but do so out of sight, leaving the student puzzled as to the lack of activity on the meter. Instructors will need to check meters regularly, and have a ready supply of new fuses.</p> <p>Similarly with digital storage oscilloscopes, the input is sampled. Repeating the action several times will help to convince the student what is going on, and may produce a good trace on the storage oscilloscope eventually.</p> <p>Fleming's right-hand (dynamo) rule needs careful explanation, and a great deal of practice, if students are to feel confident about its use. Some confuse the use of the left-hand and right-hand rules.</p> <p>An explanation is given in terms of the behaviour of electrons. The instructor should judge how far to take this with a given class of students.</p>	30 - 45 minutes
13	<p>This worksheet is designed to introduce students to the concept of inductance.</p> <p>It involves first the generation of a steady magnetic field in the core of an inductor and then observing the emf generated when the current is interrupted, causing the magnetic field to collapse. Due to the transient nature of this 'back emf', it is necessary to use a triggered oscilloscope or equivalent virtual instrument to display it.</p> <p>Some initial experimentation may be required to optimise the oscilloscope settings but those given in the worksheet make a good starting point.</p> <p>Note that the inductance used for this investigation is obtained from the primary winding of the Locktronics transformer component. This has optimum characteristics for this investigation (smaller components may produce much shorter transients which may be accompanied by a significant amount of damped oscillation resulting from the presence of shunt capacitance in the oscilloscope leads).</p> <p>Where students use a storage oscilloscope, they should be encouraged to save their screen displays and subsequently print these out.</p>	30 - 45 minutes

Tutor's notes

Intermediate electrical
and electronic principles

Worksheet	Notes for the Tutor	Timing
14	<p>In the worksheet, students are introduced to alternating current (AC) measurements.</p> <p>They are provided with an introduction to the quantities and terminology used in AC measurements. Students should understand the relationship between root-mean-square (rms), peak and peak-peak values and should be able to relate these to sinusoidal waveforms displayed on an oscilloscope.</p> <p>They should also understand the relationship between frequency and periodic time and be able to manipulate this relationship in order to calculate one from the other.</p> <p>Waveforms can be displayed using a conventional oscilloscope or a storage oscilloscope. Recommended oscilloscope settings are given in the worksheet.</p>	30 - 45 minutes
15	<p>This worksheet introduces students to the effects of inductive reactance. As students may be unfamiliar with using a signal generator, the instructor should check that it is set to the correct frequency and amplitude.</p> <p>For those returning to electrical studies after a break, this is another opportunity to revisit the use of multimeters to measure current and voltage. In particular, students should be reminded that voltage measurements can be made without interrupting the circuit, with the multimeter connected in parallel with the resistor under investigation. On the other hand, to measure current, the circuit must be broken at the point of interest, with the multimeter inserted there to complete the circuit.</p> <p>Instructors need to be aware that the low current range on most multimeters is protected by internal fuse. If a student is having difficulty in getting readings from a circuit, it may be that this fuse has blown. It is worth having spare multimeters available, and the means to change the fuses, to streamline the lesson.</p> <p>The instructions specify the signal generator output frequency, but not amplitude. This is because it is irrelevant, providing it gives measurable results. Typically, a value of 5V p-p will be sufficient.</p> <p>A comparison is made between resistors, which oppose current, and inductors, which oppose changing current. The instructor might wish to elaborate on this, and expand on what is meant by '<i>rate of change of current</i>'.</p> <p>Students may find it confusing that reactance is measured in ohms. The point should be made that this comes from the definition of inductive reactance, and a formula that looks like, but has nothing to do with, Ohm's law. The opposition caused by resistors is the resistance. However, the opposition caused by inductors is not called inductance, but inductive reactance.</p> <p>They need plenty of practice in calculating this from the formula:</p> $X_L = 2 \pi f L$ <p>as they confuse the terms f and L, and find it difficult to convert multipliers such as '<i>milli</i>' often used with inductance.</p>	30 - 45 minutes

Tutor's notes

Intermediate electrical
and electronic principles

Worksheet	Notes for the Tutor	Timing
16	<p>This is the introductory worksheet for capacitive reactance, equivalent to the earlier one on inductive reactance.</p> <p>It is important that students appreciate that inductors and capacitors are really mirror-images of each other:</p> <ul style="list-style-type: none"> • The former sets up a magnetic field, the latter an electric field. • The former has a slowly increasing current, once a voltage is applied to it. The latter has a slowly increasing voltage across it, as a current flows in the circuit. • Inductors oppose a changing current, capacitors a changing voltage. • This opposition increases with frequency in inductors, but decreases with frequency in capacitors. <p>Again, the instructions specify only the signal generator output frequency, and not amplitude. Any measurable signal can be used, providing it gives measurable results. A typical value is 5V p-p.</p> <p>The treatment given in the worksheet makes no mention of phasor diagrams, but the instructor may wish to introduce these to support the student's understanding.</p> <p>They will need plenty of practice in calculating reactance from the formula:</p> $X_C = 1 / 2 \pi f C$ <p>Students find it difficult to convert multipliers such as '<i>micro</i>' and '<i>nano</i>'.</p>	30 - 45 minutes
17	<p>Whereas series combinations of inductors, resistors and capacitors make frequency-dependent voltage dividers, parallel combinations form frequency-dependent current dividers. This worksheet introduces the first of these, the series L-R circuit.</p> <p>The treatment deliberately avoids the issue of impedance in parallel circuits, because the relevant formula is quite complicated. Instead, it looks at the currents in various parts of the circuit, and how they are related.</p> <p>Again, the instructions specify only the signal generator output frequency, and not amplitude. Any measurable signal can be used, providing it gives measurable results. A typical value is 5V p-p.</p> <p>There are phase shift issues again, and the formula given to calculate total current comes directly, but without explanation, from the phasor diagram for this circuit.</p> <p>In this case, the voltage across the components is the same. The current through the resistor is in phase with it, but the current in the inductor lags behind by 90°. The instructor must judge how much of this needs to be explained to the class.</p> <p>As before, students use their measured value of the supply voltage to calculate the currents flowing through the inductor and resistor, and then combine these to calculate a value for the total current flowing.</p> <p>The investigation is repeated for a second, higher, frequency to show that the distribution of current is frequency dependent.</p>	30 - 45 minutes

Tutor's notes

Intermediate electrical and electronic principles

Worksheet	Notes for the Tutor	Timing
18	<p>This investigation is parallel to the previous one, but for C-R (capacitor-resistor) networks. The same ideas apply. The reactance of the capacitor and the resistance of the resistor cannot simply be added together in order to determine the impedance because of the phase shift involved. Again, tutors may wish to go into this in more detail with a more able class.</p> <p>The approach is identical, except that the second frequency chosen is ten times smaller, i.e. 100Hz. Students should be encouraged to notice the similarities and differences between the two situations. Here, once again, the reactance is ten times bigger at the second frequency, and so the capacitor dominates the voltage divider at this second frequency. Amplitude is again irrelevant, but 5V p-p should give reasonable results.</p> <p>In other words, low frequencies set up large voltages across the capacitor, whereas high frequencies do so across the resistor.</p>	30 - 45 minutes
19	<p>Having studied inductors and capacitors separately, this worksheet now combines them, and introduces the concept of resonance.</p> <p>Instructors should emphasise that resonance is a widespread effect in any oscillating system. In some, such as musical instruments, it is beneficial, and students could research how the resonant frequency and so note produced, can be changed in, say, wind and string instruments. In others, particularly in civil and mechanical engineering, it can cause problems - annoying rattles in cars at particular speeds, vibrations in aircraft wings and bridges that threaten complete mechanical failure etc.</p> <p>Electrical resonance has a number of applications. The obvious one is in radio receivers, where the weak signal picked up by the aerial stimulate the tuned circuit to oscillate at its resonant frequency. Other uses include a surgical implant that kills nearby cancerous cells, when heated by stimulation at its resonant frequency through high frequency radio waves, and the widespread techniques of RFID (radio frequency identification,) where passive devices can pick up enough energy, through stimulation at their resonant frequency, to transmit information to a nearby device.</p> <p>The approach here looks at the effect on circuit impedance of changing the applied frequency. In other words, the circuit offers less hindrance to some frequencies than to others. Although there is no added series resistor, students should be made aware that the windings of the inductor coil have resistance. Amplitude is again irrelevant, but 5V p-p should give reasonable results.</p> <p>At resonance, the voltage across the capacitor is equal and opposite to that across the inductor, and so the two cancel each other out. The only hindrance to the flow of current is then the resistance of the various elements in the circuit, particularly the inductor. Equally, because the voltages across the capacitor and inductor cancel each other out, there is no reason why these cannot be very large voltages. Again, this voltage amplification effect is explored later.</p> <p>These large-scale effects occur in other examples of resonance too - the much-publicised shattering of a wine glass by an opera singer or the collapse of the Tacoma Narrows Bridge due to the effect of the wind - see videos available on 'YouTube'.</p>	30 - 45 minutes

Tutor's notes

Intermediate electrical and electronic principles

Worksheet	Notes for the Tutor	Timing
20	<p>Transformers can appear mysterious. Here, the aim is to introduce them as extensions of what has gone before. If students accept that electricity is generated when a magnet is plunged into a coil, then they should have no difficulty with the transformer. The magnet is replaced by an electro-magnet, and motion with the moving magnetic field generated by an alternating current.</p> <p>However, lack of familiarity with oscilloscope and signal generator may blur the sequence of events. Instructors may wish to give a short briefing about them to reduce these difficulties.</p> <p>It may not be obvious to some that switching a DC electromagnet on and off causes a moving magnetic field, and hence induces current in the secondary coil. Instructors may wish to develop their understanding on this through questioning them.</p>	30 - 45 minutes
21	<p>The main part of the development here is to distinguish between step-up and step-down transformers. Some students find it easy to accept 'step-down' but see 'step-up' as defying the laws of nature. It looks like something for nothing. That is why the investigation explores the effect on current, and on the overall power issues.</p> <p>The transformer used in the investigation is much more efficient than the primitive device used earlier but is still far from ideal. An ideal transformer wastes no energy and so obeys both the transformer relation and the current ratio vs turns ratio relation. The sight of cooling fins in substation transformers shows that ideal transformers are difficult to design.</p> <p>The difficulties probably centre again on the instrumentation - the use of signal generators and multimeters. The treatment of the results introduces the transformer relation, which works well. However, the issue of stepping up and stepping down current can be more problematic.</p> <p>Students should be asked to compare the use of a transformer to reduce AC voltage, with the use of a series resistor to drop some of the voltage. The transformer wins every time!</p>	30 - 45 minutes
22	<p>The practical exercise involves varying the size and direction of voltage applied to two types of diode and measuring the resulting current flow.</p> <p>Students record their measurements and then use them to plot the forward and reverse characteristics of each device. The silicon diode will not conduct measurable reverse current, and so different scales are used for the forward and reverse directions. Students should have access to sample characteristics for a variety of common devices (e.g. 1N4001 and OA91) to compare with their own graphs.</p> <p>They can be asked to suggest approximate forward conduction voltages for each diode. Generally, these are 0.6V - 0.7V for silicon diodes and around 0.1V to 0.3V for germanium devices.</p> <p>They could also be asked for applications for each type of device, or to group them as either 'power' or 'signal' devices.</p>	45 - 75 minutes

Tutor's notes

Intermediate electrical and electronic principles

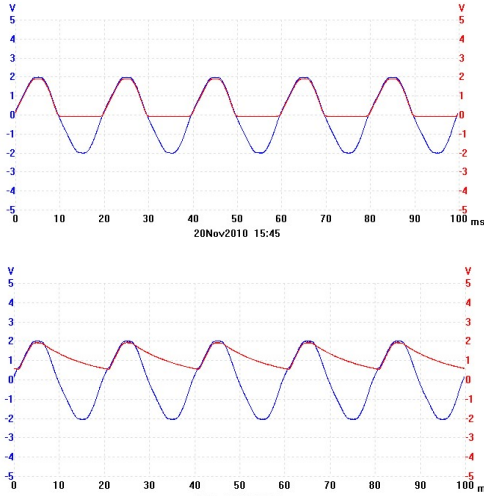
Worksheet	Notes for the Tutor	Timing
<p>23</p>	<p>In this worksheet students investigate one of the most important applications for a diode, converting alternating current (AC) to direct current (DC). They construct and test a simple half-wave rectifier . Initially they explore the operation of the circuit without a reservoir capacitor before going on to test it with four different values of capacitor. They obtain waveforms for each circuit, and should sketch them for their records.</p> <p>The input to the circuit is obtained from the nominal 12V 50 or 60Hz AC power supply (not from a signal generator as this will not usually have a low enough output impedance). Note that the 470Ω resistor is used to place a load on the rectifier circuit. Also note that '×10' probes should be used to connect the oscilloscope or equivalent virtual instrument.</p> <p>Typical waveforms for this investigation are shown below for:</p> <ul style="list-style-type: none"> no reservoir capacitor; a 47 μF reservoir capacitor. <div style="text-align: center;">  </div> <p>Students should sketch the rectified waveforms and the effect of increasing the value of the reservoir capacitance on the ripple produced by the circuit.</p> <p>More able students could be asked to measure the amount of ripple superimposed on the DC output and relate this to the time constant of the reservoir capacitor and load resistance.</p>	<p>45 - 75 minutes</p>

p68a

p68b

Tutor's notes

Intermediate electrical and electronic principles

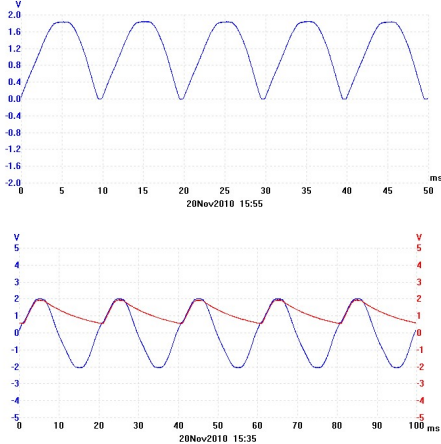
Worksheet	Notes for the Tutor	Timing
<p>24</p>	<p>In this worksheet students construct and test a full-wave rectifier arrangement. Once again, they initially explore the operation of the circuit without a reservoir capacitor before going on to test the circuit with four different values of reservoir capacitor. They obtain waveforms for each circuit, and should sketch them for their records.</p> <p>The input to the circuit is again derived from the nominal 12V 50 / 60Hz AC power supply and not from a signal generator. Note that the 470Ω resistor is used again to place a load on the rectifier circuit, and that 'x10' probes should be used to connect the oscilloscope or equivalent virtual instrument.</p> <p>Important: Students should NOT attempt to make any connection to the AC input of the bridge rectifier as this will place a short-circuit across one of the diodes of the bridge! For this reason, students are asked only to investigate the output voltage from the bridge rectifier arrangement.</p> <p>Typical waveforms for this investigation are shown below. The first is where no reservoir capacitor is used whilst the second is for a 47 μF component.</p> <div style="text-align: center;">  </div> <p>It is important for the half-wave rectifier circuit used in the previous worksheet. They should, in particular, note that the full-wave rectifier functions on both positive and negative cycles of the input waveform and that the ripple frequency is twice that of the half-wave arrangement.</p> <p>As before, students should be asked to explain the shape of the rectified waveform and the effect of increasing the value of the reservoir capacitance on the amount of ripple produced by the circuit.</p> <p>Once again, more able students could be asked to measure the amount of ripple superimposed on the DC output and relate this to the time constant of the reservoir capacitor and load resistance.</p>	<p>45 - 75 minutes</p>

Answers

Intermediate electrical and electronic principles

Answers to worksheet questions

Worksheet 1

1. 20
2. 90A
3. 12V
4. 27A
5. Different batteries may have different terminal voltages and may be in different states of charge/discharge.

Worksheet 5

1. 4k Ω
2. 1.5mA
3. 6V
4. 1mA
5. 0.5mA
6. 4V.

Worksheet 9

1. 10.3A, 345.6kJ
2. Just over 11 hours.