

## OPERATING INSTRUCTIONS

**Purpose:**

Device to acquire samples of airborne particulates. Once the particulates have been acquired a variety of chemical tests can be performed to analyze the nature of the pollutants.

**Contents:**

One (1) High Volume Air Sampler  
One (1) Manometer  
Twenty Five (25) Filter disks (8-12  $\mu\text{m}$ )  
One (1) Thermometer

**Required Accessories:**

Desiccator  
Analytical balance (1 mg accuracy)

**CAUTION**

Running the air sampler with a clogged filter may cause the unit to overheat. Reduce run times if exhaust temperature exceeds 170° F (76 C).

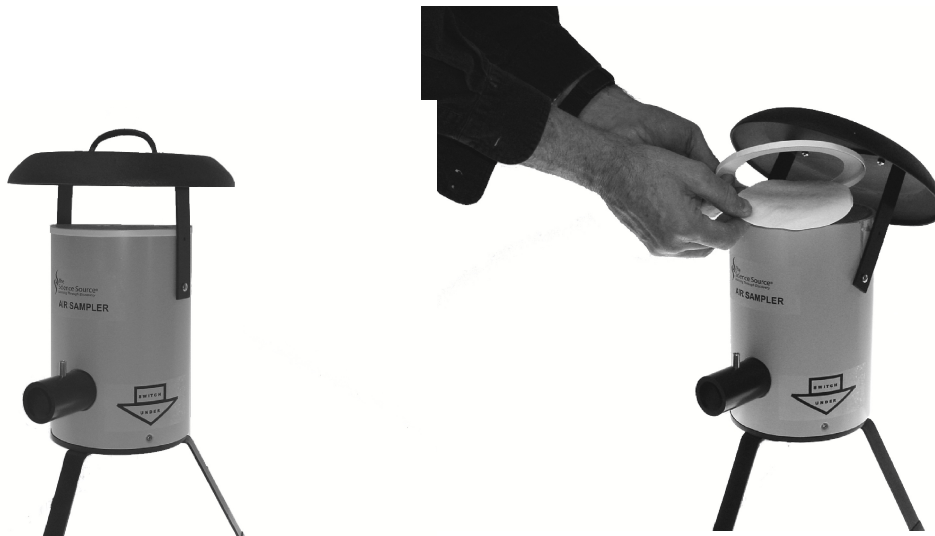

Photo showing filter installation.

## CAUTION

**Running the air sampler with a clogged filter may cause the unit to overheat. Reduce run times if exhaust temperature exceeds 170° F (76 C).**

Typically a sample collection run will be between two to four hours. However, in dusty or heavily polluted areas the sampler must not be left unattended. High concentrations of particulate matter will saturate the collection filter and restrict air flow through the air sampler. The restricted air flow will cause the air sampler to overheat. The air sampler must not operate at temperatures above 170 degrees Fahrenheit (76 degrees Celsius). If the air sampler operates at temperatures above 170 degrees Fahrenheit, plastic deformation of the sampler housing will occur and the sampler will be damaged beyond repair.

In dusty or heavily polluted environments the Air Sampler must be monitored for filter saturation and overheating. A thermometer is provided for exhaust air temperature monitoring. Periodically, (every 15-30 minutes) the sampler exhaust air temperature should be checked by holding the thermometer in the exhaust air stream for 30 seconds to collect temperature measurements. If the exhaust temperature exceeds 170 degrees Fahrenheit (76 degrees Celsius) the Air Sampler must be switched off and allowed to cool. The filter must be changed prior to operating the Air Sampler on another trial. Do not run the sampler without a filter installed while the manometer is attached and filled. The much greater flow of unrestricted air is beyond the range the manometer is designed to measure, and may eject water from the manometer slant tube.

### **Experiment #1: High Volume Particle Sampling Indoors**

One of the major indices of air pollution is the quantity of particulate matter in each cubic meter of air in the environment. A standard technique for determining the mass of particulate material in the atmosphere is to draw the air through a preweighed high efficiency (small pore size) filter at a known volumetric flow rate. The filter collects all the particulate matter in the air which passes through it. It may then be reweighed to determine its net gain. The Public Health Services, both state and federal, use this technique as the accepted standard for particulate concentration determination. This experiment uses a high pressure blower to draw particulate laden air through a filter. It does not depend on the settling out of particles and therefore samples a greater fraction of matter. It is also very accurate but only for a mass determination. Particle count and size determinations are not practical.

#### **Materials Required:**

High volume air sampler

Filter disks  
Balance capable of weighing 1 milligram

#### **Experimental Procedure:**

Using a pencil, write a sample number on the backside of a filter disk and desiccate it for several hours. When the filter has been desiccated, weigh it on an analytical balance to the nearest milligram. Record the sample number and weight.

Swivel the weather cap to one side and place a filter on the supporting screen on the top of the sampler. Hold the filter in place with the white filter cover. This also forces all of the air to pass through the filter. Return the weather cap to its vertical position. Place the sampler in a corner of the classroom or in the hall near an electrical outlet. Turn the sampler on and allow it to run for two to four hours. Be sure to check the sampler temperature at regular 20 minute intervals. Record the initial and final flow rates. This can be done by reading the pressure differential on the manometer or by allowing the sampler to inflate a large plastic bag of known volume and recording the time required to do this. To obtain the final flow rate, repeat this step just before the unit is to be turned off. Use the average of

these two flow rates in your calculations.

After sampling for a two to four hour period, carefully remove the filter paper and place it in a desiccator for several hours to remove any moisture. When the filter has been desiccated, weigh it again to determine the net gain of collected particulate material. Express your results in micrograms of material collected per cubic meter of air sampled.

If possible have some students operate the air sampler during inactive hours such as Saturday, Sunday, or before/after school when there is very little activity. Compare this data with the data accumulated from the filter paper which was placed in an area of activity.

#### Sample Calculation:

A desiccated filter had an initial weight of 3.300 grams. After sampling in the High Volume Air Sampler for 4 hours, it was desiccated and reweighed. The final weight was 3.600 grams. The initial flow rate was 700 liters per minute and the final flow rate was 600 liters per minute. Calculate the concentration of particulate matter in the sampled atmosphere in micrograms per cubic meter ( $\mu\text{g}/\text{m}^3$ ). (We will make use of the conversion factor  $10^6\mu\text{g}/\text{g}$  in the concentration calculation).

#### Net Gain (particulate mass):

Final filter weight (grams)	3.600g
- Initial filter weight (grams)	-3.300g
<hr/>	<hr/>
Net Gain (grams)	<b>0.300g</b>

#### Average Flow Rate (through filter):

Final flow rate / 2 (liters/min)	300.0 l/min
+ Initial flow rate / 2 (liters/min)	350.0 l/min
<hr/>	<hr/>
Average flow rate (liters/min)	<b>650.0 l/min</b>

#### Particulate Concentration:

(Net Mass Gain)/(Ave Flow Rate•Sampling Time)

$$0.300\text{g}/(650\text{ l/min} \cdot 240\text{ min}) = 1.923 \times 10^{-6}\text{ g/l}$$

#### Convert to the Requested Units:

$$1.923 \times 10^{-6}\text{ g/liter} \cdot 10^6\mu\text{g/g} \cdot 10^3\text{ liter}/\text{m}^3$$
$$\text{Particulate concentration} = 1.923 \times 10^3\mu\text{g}/\text{m}^3$$

#### Experiment #2: Indoor sampling vs Outdoor sampling

The assessment of exposure of population groups to air contaminants must be based upon an appraisal of all environments in which that exposure occurs. The indoor environment is of considerable importance, since metropolitan populace spends far more time indoors than out. In northern latitudes during the winter (heating) season, the proportion of time spent indoors is maximized. It is also during the winter season that air contamination is most severe. This experiment will demonstrate the degree of protection from pollution which a building affords the people inside.

#### Materials Required:

(This experiment can be run with one sampler, but two samplers will make the testing more accurate)

High Volume Air Sampler  
Filter disks  
Balance capable of weighing 1 mg.

#### Procedure:

Operate the sampler for 1 hour in the class room as explained in Experiment #1. Remove the filter paper and put it in a desiccator. Put a second piece of desiccated filter paper into the sampler. Place the sampler just outside the window of the room and sample for 1 hour. Repeat this testing procedure several times to obtain a good statistical analysis. Perform this testing for at least a week. Which papers show the highest contaminant concentrations?

If two samplers are available, they should be operated simultaneously; one inside the class and the other outside the window. Make your calculations as explained in experiment #1. Can you correlate the degree of pollution with any activity such as rush hour traffic?

#### Experiment #3: Air Pollution Analysis

(This experiment has been reproduced from "The chemical Analysis of Air Pollutants" by Morris Jacobs, Ph.D. through the courtesy of John Wiley & Sons, New York and is suitable for advanced senior high school or college level courses).

#### Introduction:

Many times it is very important to determine not only the total mass of particulate material in the atmosphere, but also what and how much of each component is in the air. This section gives techniques

and details for analyzing quantitatively what is in the air we breath. The following procedures can be quite involved and difficult to perform due to the extremely small sample sizes. Therefore, the following material is provided to illustrate the various techniques used to analyze unknown materials. If you are fortunate enough to have access to chemical laboratory facilities, you may wish to try them your self.

#### **Materials Required:**

Carbon dioxide gas  
Sodium sulfate, anhydrous  
Graduated cylinder, 100 ml  
Several 250 ml flasks  
Analytical balance  
Sodium hydroxide, solid  
Hydrochloric acid  
Several small tared (weighed) flasks  
Chloroform or ether alcohol  
Fritted glass funnel, medium porosity, weighed  
Hot plate  
Two Separatory funnels

#### **Procedure:**

- 1) Sample the air for at least 4 hours as described in Experiment #1.
- 2) Cut the sample into 12 equal pie shaped pieces (every 30 degrees).
- 3) The wedges, each of which represents 8.33 percent of the original sample, are used as follows: Extract two wedges and use for the determination of sulfates, nitrates, and pH. Use two wedges for the determination of fluorides and hold two wedges in reserve. These portions may be used for other analyses if desired.

#### **Determination of Water Soluble Particulate Matter:**

A preliminary separation into insoluble, water soluble, and ether soluble fractions is made. Weigh the sample in a small tared flask. Loosen the sample by the addition of a small amount of chloroform or ether alcohol. Add 100 ml of ethyl ether to the flask and rotate to assist in the solution of the specimen. Filter the test solution through a weighed medium porosity fritted-glass funnel. Repeat the ether treatment. Wash the residue in the flask with 25 ml of water and filter through the same fritted funnel. Repeat the water washing procedure. Dry the flask and funnel then weigh to determine the amount of insoluble material.

Transfer the ether-water mixture to a separatory funnel. Rinse the container with small amounts of ether and water adding these rinsings to the separatory funnel. Shake fairly vigorously, then allow to stand until the two layers separate. Draw off the water layer into a clean flask. Add 100 ml of water to the separatory funnel. Shake fairly vigorously and again allow the layers to separate. Draw off the water layer into the same flask used for the first extract.

Transfer the combined water extracts to another separatory funnel and extract with 50 ml of ether. Draw off the water layer and evaporate to a small volume in a hot plate. Transfer the solution to a small weighed flask and evaporate to dryness. Weigh this as the water-soluble fraction.

Combine the ether solution remaining in the preceding operation with that reserved above and use this ether solution for isolation of the basic groups.

#### **Isolation of Basic Groups:**

Combine the ether extracts in one separatory funnel and add 60 ml of 1 N hydrochloric acid. Shake fairly vigorously then allow to stand until the two layers have separated completely. Draw off the lower layer into a clean flask and repeat the acid extraction using 60 ml of 1 N hydrochloric acid. Add the second acid layer to the first. Wash the ether solution in the separatory funnel with a small amount of water without shaking. Add the wash water to the acid extracts. Transfer the acid extract to another separatory funnel and extract with 25 ml of ether. Draw off the acid solution into a flask. Add the ether to the other extracts remaining in the separatory funnel and save for the isolation of acid groups. Add the ether to the other extracts remaining in the separatory funnel and save for the isolation of acid groups.

Add solid sodium hydroxide cautiously to the acid extract until the solution is alkaline. Transfer to a separatory funnel and extract twice with 80 ml portions of ether. Discard the acid layer after the second extraction. Wash the combined ether extracts with a small volume of water with gentle shaking. Discard the wash water.

Transfer the ether solution to a dry flask containing 10 to 15 grams of anhydrous sodium sulfate. Rotate gently to mix, stopper carefully, and allow to stand several hours or overnight. Filter the dried ether solution through a small filter paper of fritter glass funnel into a dry flask. Be sure to wash the original flask, containing the sodium sulfate with

several portions of anhydrous ether adding these washings to the other ether solution. Carefully evaporate in a hood to a small volume. Transfer the solution to a tared weighing bottle or test tube rinsing the flask with small amounts of ether. Evaporate to constant weight spontaneously or at a temperature below the boiling point of ether. This is the basic or amine fraction.

#### **Isolation of Acid Groups: All Acids**

Extract the combined ether from the basic group separation twice with 60 ml portions of 5 per cent sodium hydroxide solution and place the extracts in a separatory funnel. Wash the ether layer with a small volume of water and add the water to the alkaline extracts. Extract the combined alkaline solutions with 25 ml of ether and add this extract to the ether remaining above. Reserve for isolation of neutral groups.

Acidify the alkaline solution with concentrated hydrochloric acid to pH 1 to 2. Extract twice with 60 ml of ether. Combine the ether extracts, place in another separatory funnel, and wash with a small volume of water. Discard the water layer. Transfer this ether layer to a flask containing 10 to 15 grams of anhydrous sodium sulfate, agitate gently, stopper, and allow to stand for several hours or overnight. Filter the solution into a dry flask and wash the flask containing the anhydrous sodium sulfate and filter several times with anhydrous ether catching the washings in the flask containing the filtrate. Carefully evaporate to a small volume, transfer to a tared weighing bottle or test tube, and evaporate to constant weight. The residue is the acid fraction.

#### **Isolation of Acid Groups: Weak Acids and Strong Acids**

Repeat the above procedure for the isolation of all acids. Bubble carbon dioxide through the alkaline solution obtained until a pH of 8 is produced.

Extract this solution twice with 60 ml of ether. Combine the ether extracts, place in another separatory funnel, and wash with a small volume of water. Add the water to the previously extracted slightly alkaline solution. Dry the ether layer with anhydrous sodium sulfate as detailed. Filter the dried ether layer into a flask, and wash the flask containing the sodium sulfate as detailed. Filter the dried ether layer into a flask, and wash the flask containing the sodium sulfate and the filter several times with anhydrous ether. Carefully evaporate to a small volume, transfer to a tared

weighing bottle or test tube, wash the flask with small portions of anhydrous ether, and evaporate to constant weight. This gives the weak acid fraction.

Acidify the weakly alkaline solution with hydrochloric acid to a pH of 1 to 2. Extract twice with 60 ml of ether. Combine the ether extracts, place in another separatory funnel, and wash with a small volume of water. Discard the water layer. Transfer the ether layer to a flask containing 10 to 15 grams of anhydrous sodium sulfate, shake gently, stopper, and allow to stand overnight. Filter the dried ether solution into a dry flask and wash the flask containing the sodium sulfate and the filter with several portions of anhydrous ether. Carefully evaporate to a small volume, transfer to a tared weighing bottle and evaporate to constant weight. This gives the strong acid fraction.

#### **Isolation of Neutral Groups:**

Transfer the ether solution reserved for the isolation of the neutral group to a flask containing several grams of anhydrous sodium sulfate, shake gently, stopper, and allow to stand several hours or overnight. Filter through a fritted filter into a clean flask. Wash original flask and funnel with several portions of anhydrous ether and catch the washings in the same flask. Carefully evaporate the ether solution to a small volume then transfer to a tared weighing bottle or test tube. Evaporate to a constant weight. The residue is the neutral fraction.

#### **Experiment #3: Detection and Measurement of Radioactive Particulate Matter in the Atmosphere**

As the rate of radioactive material usage increases it is inevitable that an increase in the ambient radioactivity level of the atmosphere will be noted. It is extremely important that the levels be monitored to enable scientists to make predictions relative to the future of mankind with respect to radioactive increases. This experiment deals with the measurement of radioactive particulate matter in the atmosphere.

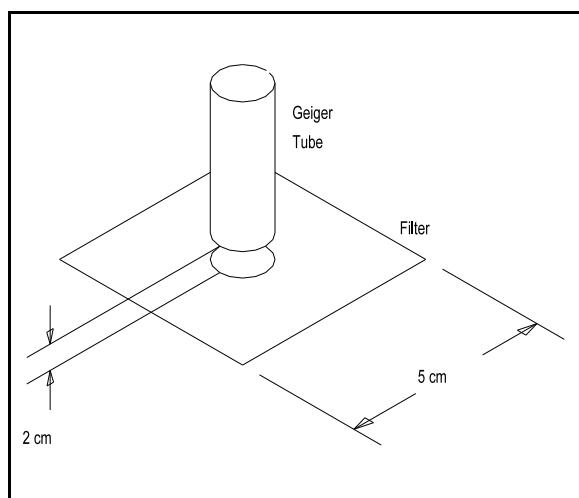

**Figure 4**  
Placement of filter paper and Geiger Tube to test for radioactivity.

#### Materials Required:

High Volume Air Sampler  
Filter disks  
Geiger counter

#### Procedure:

Cut a small piece of filter paper approximately 5 cm by 5 cm square and place it in a radioactivity counter to get a background count on radioactive particles on the paper (Figure 1).

Place a filter disk in the air sampler and replace the weather cap. Place the sampler outside and let run for four hours. Record the initial and final air flow rates. Remove the filter paper from the sampler and cut a 5 x 5 cm square from the middle of the filter paper. Insert this square into the counter to determine the level of radioactivity as compared to the background count made previously. The same filter should be measured for radioactivity again in 24 hours. This will allow Thorium B (half life = 10.6 hours) and the Radon daughters which have a much shorter halflife to decay completely.

#### Use and Care of the High Volume Air Sampler.

Use caution when using filters other than those supplied with the instrument. If the filter pore size is too small the air flow through the sampler will be restricted and result in overheating.

This air sampler is designed for normal operation in the 50 to 76 degree Celsius range. The temperature of the air exiting the sampler should not exceed 76

degrees Celsius or go below a flow rate of 400 liters/minute. If this operating temperature is exceeded, permanent damage to the sampler housing may result. Remember, as the filter collects particles, the flow rate will decrease. Therefore, if the filter becomes excessively clogged, the flow rate will drop and the sampler may overheat. Do not leave the sampler unattended.

The sampler may be cleaned with mild soap and water. Do not allow water to enter the sampler. Do not use solvents (alcohol, acetone, paint thinner, etc.) to clean the air sampler. Keep the filter support screen clean and dry at all times.

The supplied filters provide an average flow rate of ~700 l/minute when clear. The slant tube manometer supplied with the sampler has been designed to measure flows up to ~1000 l/min. Use caution when substituting filters, as filters that are too fine may restrict the air flow and result in overheating. More porous filters will cause the manometer to rise above its designed capacity and may cause spillage. The instrument must be recalibrated if filters outside of the manometer's design range are used.

To calibrate the air sampler, first disconnect the manometer tubing from the aluminum ports. Attach a large plastic bag of known volume (the volume can be calculated) to the exit port of the air sampler (a rubber band works nicely). Place a clean filter on the filter support screen and secure in place with the filter cover. Turn the sampler on and record the time required to fill the bag. Dividing the volume of the bag by the time required to fill the bag. This is the flow rate of the sampler in liters/second. This procedure should be done at the beginning and end of each experiment.

The electrical load of the running sampler should be less than 1000 watts. Use appropriately rated extension cords if necessary to reach the test location. Flow rate calibration activities should be conducted under the actual test conditions.

#### Time Allocation:

To prepare this product for an experimental trial should take less than ten minutes. Actual experiments will vary with needs of students and the method of instruction, but are easily concluded within one class period.

#### Feedback:

If you have a question, a comment, or a suggestion that would improve this product, you may call our toll free number **1-800-299-5469**, or e-mail us:

**info@thesciencesource.com**. Our fax number is: **1-207-832-7281**.

**Appendix: Using the 15005 Manometer**

**Manometer Contents:**

- One graduated slant tube manometer block
- One 2 ft length of manometer tubing
- One syringe
- One stopper

**Recommended additional materials:**

- Celsius thermometer
- Local weather data

The manometer supplied with the Air Sampler is a handy tool that can be used to calculate volumetric airflow during a particle sampling experiment. Approximate air flow values are provided in the 15000 Air Sampler instructions but more accurate calculations can be derived using the height of a water column displaced by the difference between static pressure and total pressure of air in the exhaust port.

**Procedure:**

Affix the manometer block to the air sampler housing by mounting its aluminum plate to the left threaded stud of the weather cap, as viewed from the exhaust side. Using the syringe, inject approx. 20ml into the manometer cylinder through the stopper hole. The meniscus should be at the indicating mark on the backing plate. Replace the stopper. The manometer is level when this meniscus is at its line and the meniscus in the slant tube is at the beginning of the scale. Adjust the angle of the manometer block and/or the volume of water added until this is achieved. The water column in the slant tube should be “reset” during adjustment by gently blowing into the slant-tube hose until air bubbles up in the chamber and then allowing the water to again find its level. The column itself should always be free of air bubbles. Dislodge any water droplets clinging inside the air tubes. Attach the manometer tubing emerging from top of the manometer cylinder (high pressure) to the aluminum port on top of the air sampler exhaust. Attach the low pressure tube to the port beneath the exhaust pipe. Make sure a clean filter is installed in the air sampler.

The upper aluminum fitting can be seen to be directed into the flow of the exhaust port. This produces a region of pressure above the column of water in the manometer cylinder that is equal to the total pressure of air within the exhaust pipe,  $P_{tot}$ . This total pressure consists of the pressure of the moving or dynamic air,  $P_{dyn}$ , and the static pressure of the air in the system,  $P_{stat}$ :

$$P_{tot} = P_{dyn} + P_{stat}$$

The region above the water of the slant tube is at  $P_{stat}$ , as it is connected to the lower aluminum fitting which is perpendicular to the air flow. The difference in  $P_{tot}$  and  $P_{stat}$  results in movement of the column of water upward until that movement equals the hydrostatic pressure of the column. The height of the water column therefore represents  $P_{dyn}$ .

The manometer’s slant tube is set at 4 degrees from horizontal. Note that its scale measures the extension of water along the hypotenuse, not vertical displacement. Hence,

$$P_{dyn} = \rho g h = \rho g (d \sin \theta)$$

where:

- $\rho$  = density of fluid (water),  $\text{kg/m}^3 = 1000$
- $g$  = acceleration due to gravity,  $\text{m/s}^2 = 9.8$
- $h$  = height of fluid column, m
- $d$  = extension along the slant scale, m
- $\theta$  = angle of slant tube

This gives us  $P_{dyn}$  in Pascals. From Bernoulli, we know that the dynamic pressure of a fluid is related to its velocity. We can apply the  $P_{dyn}$  we just calculated to his equation:

$$P_{dyn} = 1/2 \rho v^2$$

where:

$$\rho = \text{density of fluid (air), kg/m}^3 \text{ (see below)}$$

$$v = \text{velocity of fluid (m/s)}$$

Rearranging,

$$v = (2 P_{\text{dyn}} / \rho)^{0.5}$$

We now have a measure of the velocity of air in the exhaust pipe. Multiplying this by the cross-sectional area of the pipe gives us flow:

$$F = v(\pi r^2)$$

where:

$$F = \text{flow, m}^3/\text{s}$$

$$r = \text{radius of exhaust pipe, m} = 0.026$$

Flow can finally be converted into whatever units are preferred and then divided by distance traveled on the slant scale for quick reference in future trials.

Upon startup of the air sampler, the manometer will require several minutes to equilibrate to its full height. Similarly, the column recedes very slowly when pressure is removed or is diminished. For best results, when measuring a lower flow following a higher one, such as at the end of a sampling run where flow is diminished due to particulate in the filter, “reset” the water column as described above and take a final reading.

**Correcting for air density:**

Greater accuracy in flow measurement can be achieved by taking additional steps in calculating  $v$  from  $P_{\text{dyn}}$ . It can be seen that this determination is sensitive to air density, which is in turn affected by temperature, local atmospheric pressure, and humidity.

*Temperature correction is highly recommended.* The air sampler’s motor generates heat, and affects the temperature of the air it pushes. Therefore, the density of the exhausted air changes significantly from resting to operational values. If possible, the exhaust temperature should be measured with a thermometer. Dry air density can then be approximated by the ideal gas law:

$$\rho = P / (R_d * T)$$

Where:

$$\rho = \text{density of fluid (air), kg/m}^3$$

$$P = \text{air pressure (standard), Pa} = 101325$$

$$R_d = \text{gas constant of dry air, J/(kg*}^\circ\text{K)} = 287.05$$

$$T = \text{temperature (exhausted air), }^\circ\text{K}$$

Further correction for local atmospheric pressure and humidity is less important, but these values may easily be obtained from weather websites. Using these, a very accurate value for air density is calculable using the ideal gas law and a function for the partial pressure of water vapor:

$$\rho = [P_d / (R_d * T)] + [P_v / (R_v * T)]$$

Where:

$$P_d = \text{pressure of dry air (standard), Pa} = 101325$$

$$P_v = \text{pressure of water vapor in air, Pa}$$

$$R_v = \text{gas constant of water vapor, J/(kg*}^\circ\text{K)} = 461.50$$

The partial pressure of water vapor (in Pa) may be estimated by local dewpoint ( $T_{\text{dp}}$ ,  $^\circ\text{C}$ ) by the function:

$$P_v = 610.78 * 10^{[(7.5 * T_{\text{dp}}) / (237.3 + T_{\text{dp}})]}$$



Since local pressure is the sum of all partial pressures, partial pressure of dry air ( $P_d$ ) is simply difference between local pressure (in Pa, from weather data) and what we have calculated for  $P_v$ :

$$P_d = P_{loc} - P_v$$

**Sample calculation:**

manometer travel: 30 mm (0.030 m)  
 exhaust temperature: 50°C (323 °K)  
 local pressure: 1012.4 mb (101240 Pa)  
 dewpoint: 14°C

1. Find  $P_v$ , the partial pressure of water vapor:

$$P_v = 610.78 * 10^{[(7.5 * T_{dp}) / (237.3 + T_{dp})]} = 610.78 * 10^{[(7.5 * 14) / (237.3 + 14)]} = 1598.5 \text{ Pa}$$

2. Find  $P_d$ , the partial pressure of dry air:

$$P_d = P_{loc} - P_v = 101240 - 1598.5 = 99641.5 \text{ Pa}$$

3. Find  $\rho_{air}$ , air density:

$$\rho_{air} = [P_d / (R_d * T)] + [P_v / (R_v * T)] \\ = [99641.5 / (287.05 * 323)] + [1598.5 / (461.50 * 323)] = 1.085 \text{ kg/m}^3$$

4. Find  $P_{dyn}$ , dynamic air pressure:

$$P_{dyn} = \rho_{water} g h = \rho_{air} g (d \sin \theta) = 1000 * 9.8 * 0.030 * 0.070 = 20.58 \text{ Pa}$$

5. Find  $v$ , fluid (air) velocity:

$$v = (2 P_{dyn} / \rho_{air})^{0.5} = (2 * 20.58 / 1.085)^{0.5} = 6.159 \text{ m/s}$$

6. Find  $F$ , flow:

$$F = v (A) = 6.159 (0.026^2) = 0.013 \text{ m}^3/\text{s} = 780 \text{ l/min}$$