

ALTERNATOR CONSTRUCTION

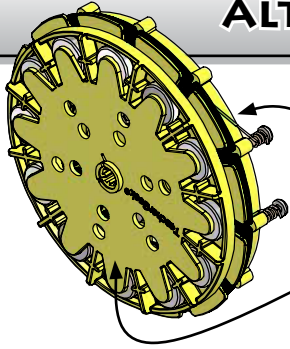

Stator [stey-ter]
The portion of the alternator that remains fixed. An electrical current is induced in its coils when rotor magnets pass.

Rotor [roh-ter]
The rotating member of the alternator containing a circular array of magnets.

This guide will take you through the process of creating a standard single phase alternator. Other alternator configurations can be found at TeacherGeek.com.

! WARNING!!!

Strong Magnets. Handle magnets with care to prevent injury or damages. Keep away from medical devices. Not for children under 8 years old. Components pose a choking hazard.

TOOLS NEEDED

Phillips Screwdriver



600 Grit Abrasive Paper or a Nail File



Cutters



This is what an alternator from a car looks like.

PARTS NEEDED

TO BUILD ONE ALTERNATOR

Two 2.5 x 8mm (small) Screws
Two #10x 1in (large) Screws



12 Neodymium Magnets [nee-oh-dim-ee-uhm]



18.2g (.4lbs) of Magnet Wire 30awg Standard

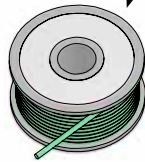

One Rotor

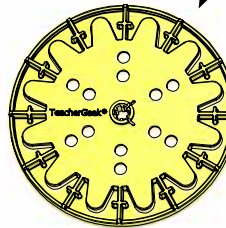

One Stator

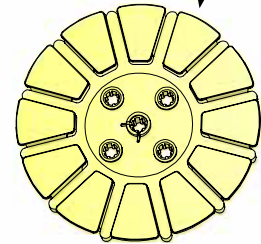

1. MAGNET MARK

It's a good idea to mark the same pole side on each magnet as you take them apart, or on the TeacherGeek magnet alignment block.

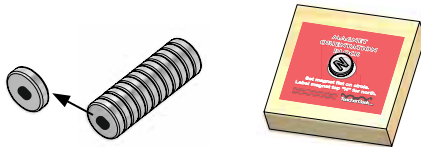

2. ROTOR BUILD

Snap magnets around the rotor, alternating magnet polarity.

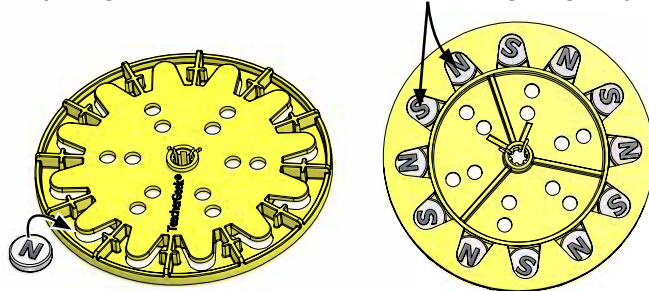

TIPS

Use a table with a sharp edge to break magnets apart.



Magnets can be removed by gently pushing them up and out with a straight screwdriver.



3. STATOR BUILD

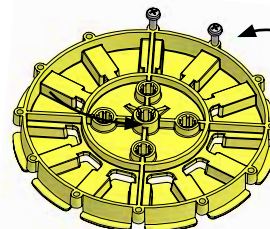

Turn two 2.5 x 8mm screw into neighbouring stator holes.

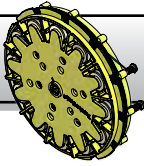

ALTERNATOR CONSTRUCTION

Coils must now be created by wrapping magnet wire around the Stator Teeth (all 12 of them).

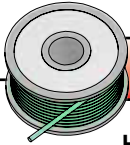

3A. GET YOUR WIRE

How much wire do you need? One stator needs around .04lbs (18.2g) of wire. Use the chart below to find the length you will need and the total number of wraps you should have on each stator coil.

If you have a turbine 12 Pack, you will have to split/share the provided wire between stators.

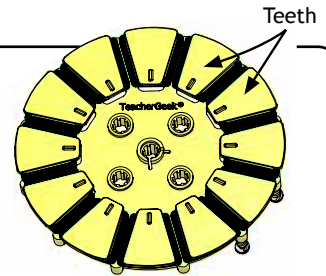

Kits come with 30awg wire.

Wire For One Stator			
Gauge	Weight	Length	Wraps per Tooth/Coil
28	.04lb (18.2g)	90ft	30
30		190ft	50
32		230ft	60

Alternator performance changes based upon the gauge wire used and wraps per coil.

3B. REMOVE INSULATION

Scrape, Sand or file .75in (19mm) of enamel off the end of the magnet wire.

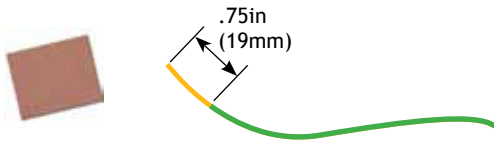

TIP

Label each stator tooth with a number and arrow indicating the coil wrap direction.



3C. WRAP THE COILS

Wrap the un-insulated wire end around terminal "A". Then neatly coil the wire around each stator tooth. The chart aside recommends how many wraps to have on each coil. When you have finished coiling around all stator teeth, trim and remove insulation from the wire end and wrap it around terminal "B."

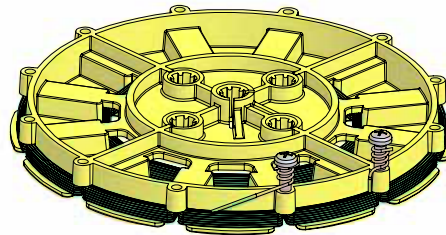

Labels: Screw Terminal "A" Wire Start Here, Screw Terminal "B" Wire End Here, Coils are wound in alternating directions.

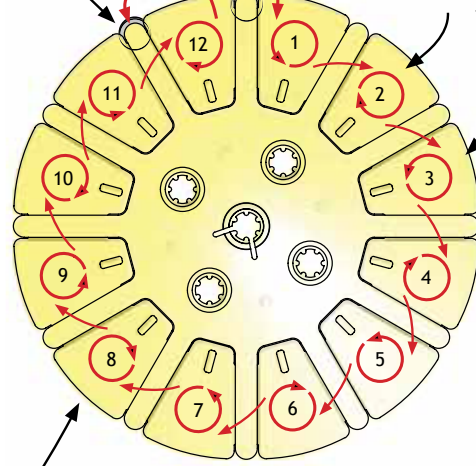

The arrows show the direction to coil the wire around each stator. Notice that every other coil is wound in the opposite direction.

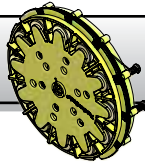

ALTERNATOR CONSTRUCTION

4. PREPARE FOR MOUNTING

Insert two #10 x 1in machine screws and ream the center hole. This will prepare the stator for mounting.

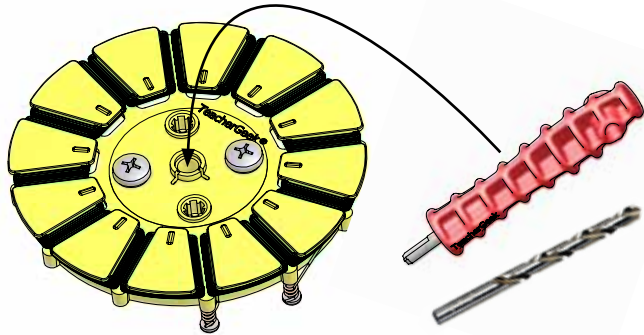

- Ream using on of the following:
1. TeacherGeek Reamer (best)
 2. 15/65 or 6mm drill bit

- ! Note: Only ream the center hole.
- Do not ream the rotor, or any other hole.

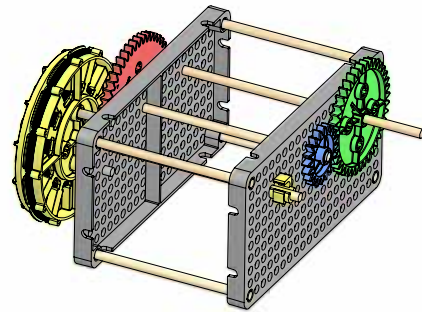
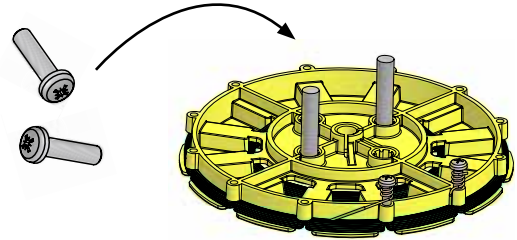

Your alternator is now ready to be put on a turbine or attached to a gearbox.