

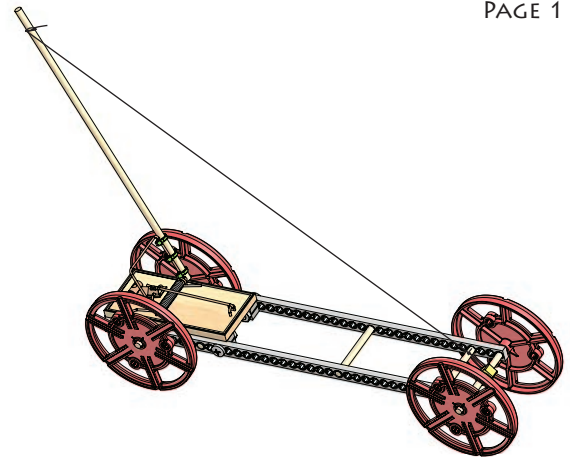

THE ACTIVITY

Build, race and re-engineer a rubber band powered vehicle while applying the science concepts of energy, simple machines and friction.

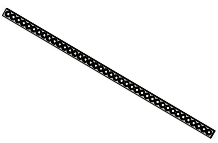
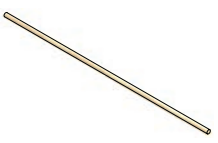
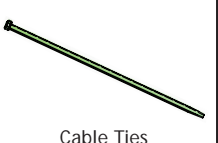
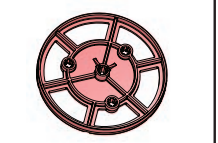

WHAT WILL YOU NEED?

Materials to build one mousetrap vehicle:

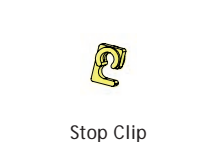
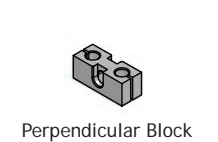
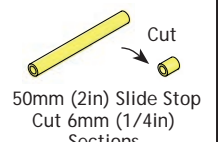
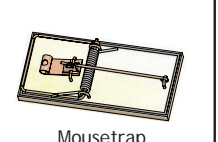
 Connector Strips Quantity: 4	 300mm (~12in) Dowels Quantity: 4	 Cable Ties Quantity: 4	 Wheel Hub Quantity: 4	 Stretch Tire Quantity: 2	 #6 Wood Screw, 5/8in Quantity: 4
 Stop Clip Quantity: 2	 Perpendicular Block Quantity: 6	 50mm (2in) Slide Stop Cut 6mm (1/4in) Sections Quantity: 1	 Mousetrap Quantity: 1		

Required materials, not included:







Suggested materials, not included:

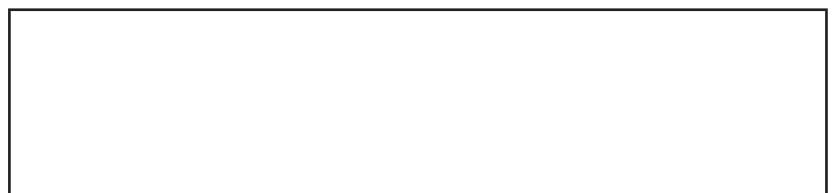

Other approved materials:

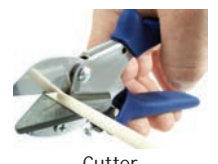
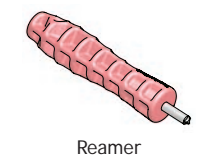

Tools to Build a Mousetrap Vehicle:

 Cutter	 Reamer	 Optional: Wax, Soap or Crayon	 Optional: Hammer	 Optional: Pliers
---	---	---	--	---

Build it, test it, change it. TeacherGeek™ components allow you to design and engineer your most imaginative mechanisms. Combine them with other materials and products. More resources are available at teachergeek.com.

DOWELS

Dowels vary in diameter. Some may be too large or small to use.

The ends of dowels may taper and need to be cut off to fit tightly into holes.

CUTTING

Dowels and Connector Strips can be cut with a multi-cutter (best method), saw, side cutters or pruning shears. Wear safety glasses when cutting.



Multi-Cutters

HOLES & REAMING

Components come with holes that dowels press securely into.

Reaming holes to allow dowels to rotate and slide freely.

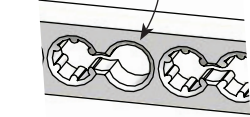

Turn a reamer back and forth through a hole.

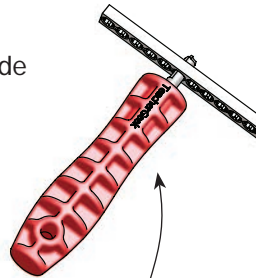

PUSH, WIGGLE, TAP

Push dowels into holes by:

1. Wiggling and pressing with your hands
2. Tapping dowels with a hammer or the side of your cutter.

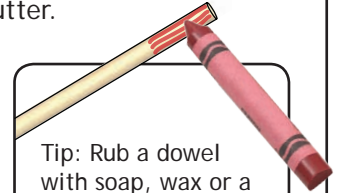
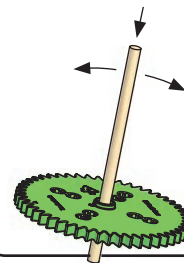

Tip: Rub a dowel with soap, wax or a crayon to allow it to slide easier into and out of holes.

START BUILDING!!!



WARNING!!! Most holes should not be reamed. Do not ream holes which dowels should stay pressed into.

STEP #1

Cut four 55mm (~1 3/8in) dowels.

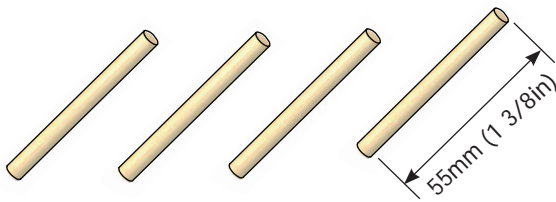

STEP #2

Slide perpendicular blocks onto two dowels from Step #1.



Do not ream.

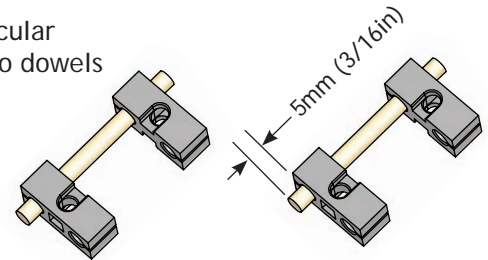

STEP #3

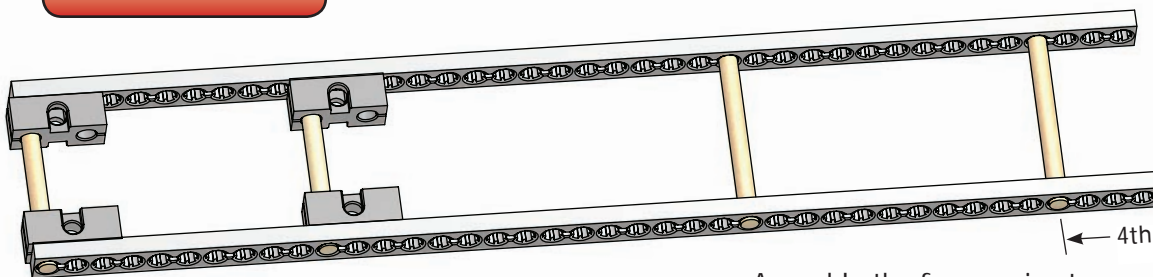

Do not ream.

Assemble the frame using two perpendicular blocks and parts from Step #1 and #2.

OPTIONAL

Optional: If you have #10 machine screws and nuts, you can use them to fasten the inside perpendicular blocks.

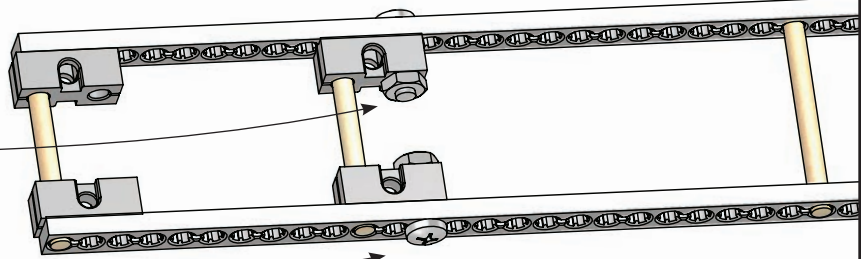
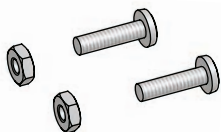

STEP #4

Use four #6 screws to attach the mousetrap to the perpendicular adaptors on the frame.

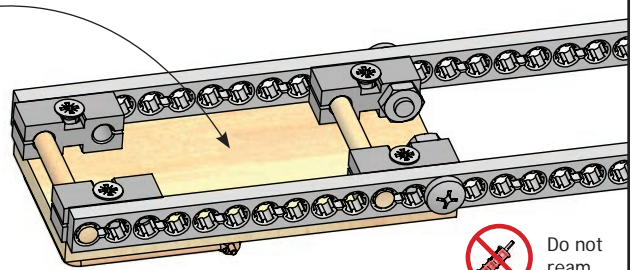
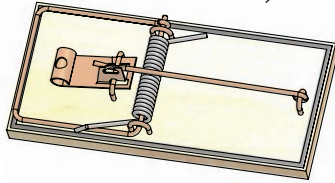

Do not ream.

STEP #5

Use three cable ties to attach a dowel to the mousetrap lever arm. Make sure they are tight!

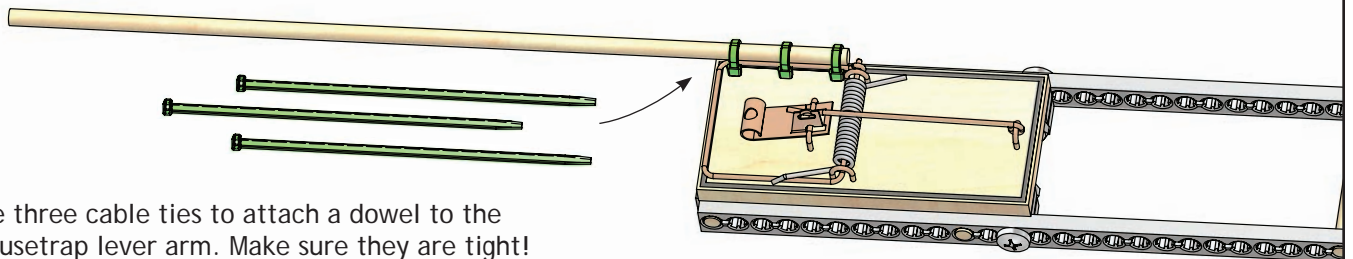

STEP #6

Ream the holes marked with an .

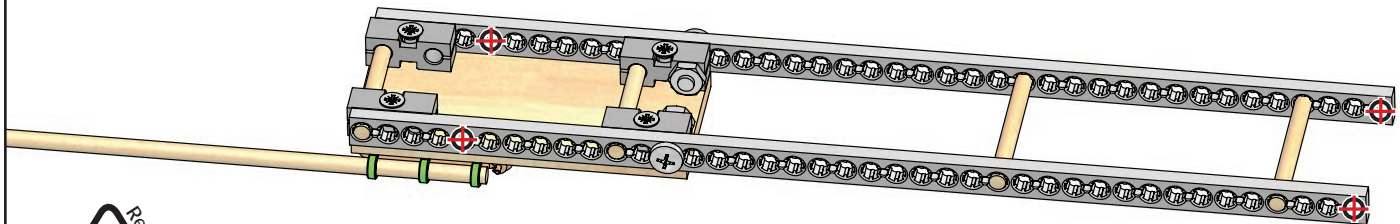

STEP #7

Cut two 85mm (~1 3/8in) dowels and place them into wheels.

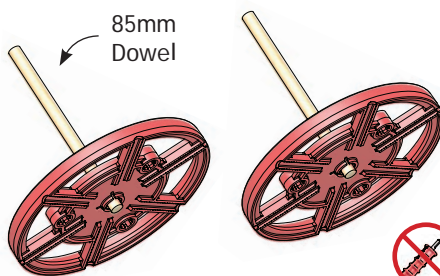

STEP #8

Place the wheel assemblies from Step #7 into the reamed holes in the frame.

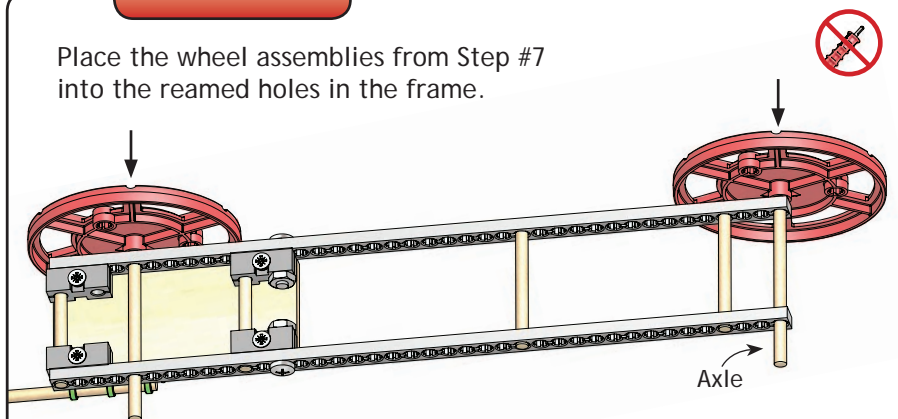

TIP: REDUCE FRICTION

Friction is the force resisting the motion of surfaces sliding against each other.

STEP #9

Attach the last two wheels.

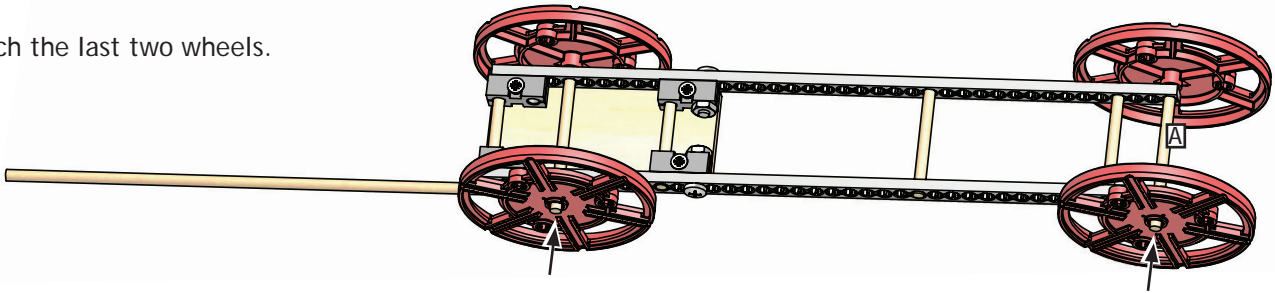

STEP #10

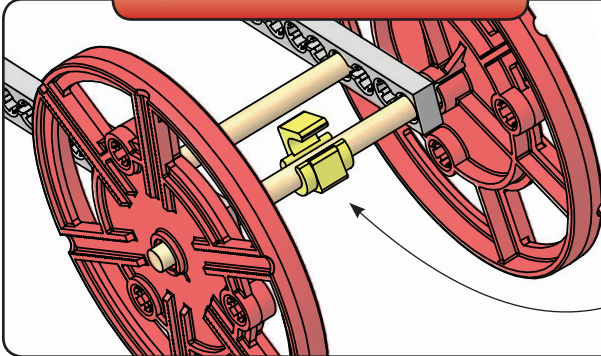

Snap a stop clip onto the axle marked **A** in the picture above. Position it as shown.

Snap on the stop clip by pushing downward.

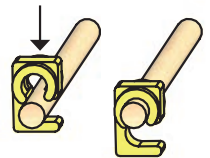

Attach the stop clip so the "hook" is facing away from the racer when up.

STEP #11

The stop clip may slip (rotate on the axle) when pulled by a rubber band. This can be prevented with a drop of glue.

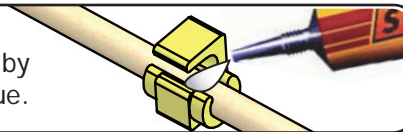

STEP #12

A) Cut a 75cm (~30in) length of string (not included).

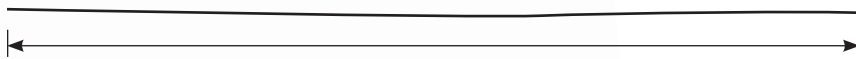

B) Tie a loop, that will not slip, at one end of the string.



C) Tie the end of the string without the loop to the dowel.

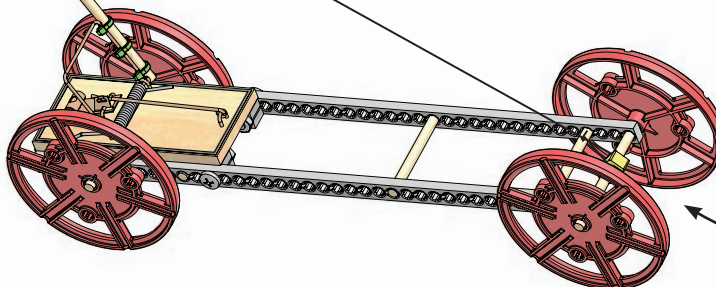

D) Hook the loop onto the stop clip on the axle.

OPTIONAL: ADD TRACTION

Rubber tires can be stretched around your wheels to provide traction.



Tip: Applying glue to the outside of the wheel will help the stretch tire stay on (after it dries).

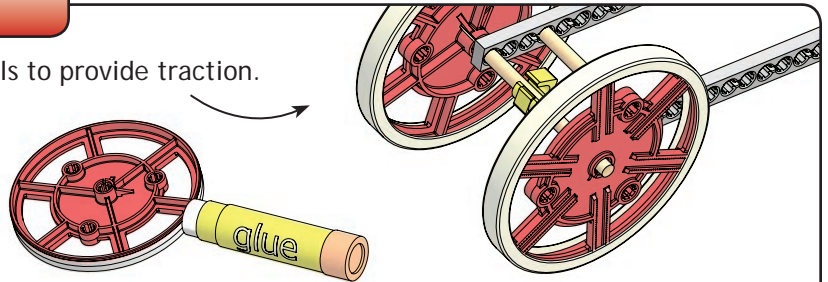

INNOVATE!!!

It is now time for you to re-engineer and evolve your mousetrap vehicle. Extra components have been included to help you do this.

Ideas:

- Create a New Frame/Layout
- Develop Better Power Transfer
- Reduce Friction
- Optimize Mechanisms
- Give it Personality

2ND LEVER ARM

A 2nd lever can change the way power transfers from the mousetrap to the axle.

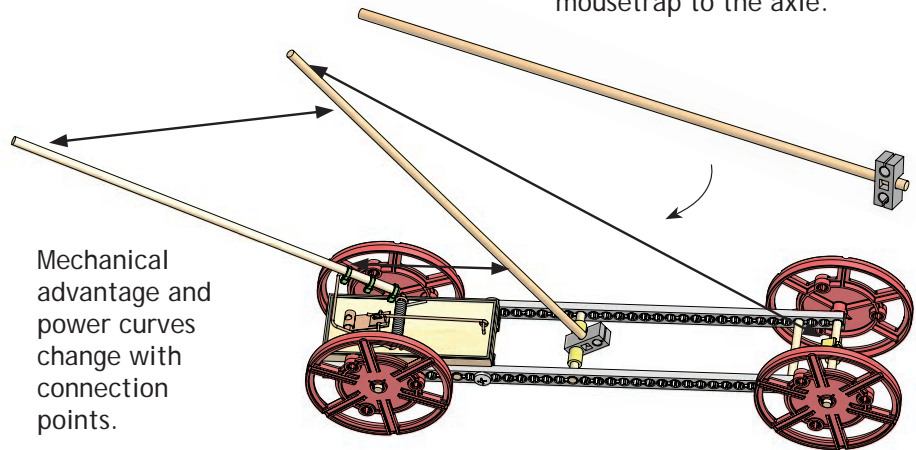

Mechanical advantage and power curves change with connection points.

EXTREME CHALLENGES

Extreme Distance

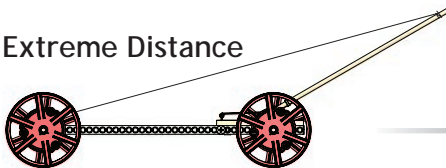

Slow & Far

Dragster

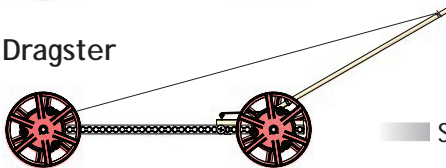

Short & Fast

All-Terrain

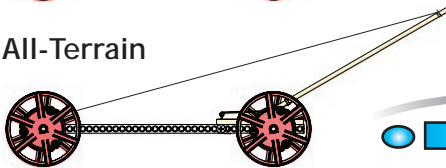

Over Terrain

Precision Stop / Shuffleboard



Precision Distance

It's time to re-engineer your mousetrap vehicle to compete in extreme challenges. Build it for one competition, then re-engineer it for another.

**NO DESIGN IS EVER PERFECT.
CONTINUE TO EXPERIMENT, RE-ENGINEER
AND EVOLVE YOUR DESIGN.**